

# **TEXTBOOK OF BASIC BIOTECHNOLOGY**

**Dr. A. AMSATH, M.Sc., M.Phil., Ph.D.,**  
Associate Professor and Research Advisor  
PG and Research Department of Zoology  
Khadir Mohideen College, Adirampattinam-614701, Thanjavur Dt.

**2008**

**M. M. A. PUBLICATIONS**  
6B/2 Ever Gold Complex,  
Selliamman Kovil Street,  
Adirampattinam-614 701, Thanjavur Dt.

**Title: TextBook of Basic Biotechnology**

**First Edition: 2006**

**Revised Second Edition: 2008**

**Published by:**

**M. M. A. Publications**

Professor Manzil, 269-A Bharathisalai, Karikkadu,  
Pattukkottai - 614 602.

**Author**

**Dr. A. AMSATH**

Associate Professor  
PG and Research Department of Zoology  
Khadir Mohideen College  
Adirampattinam-614 701

**Cell : 94437 17126**

## PREFACE

Biotechnology is one of the recent emerging fields because of its importance in areas like, biochemical, agricultural, animal husbandry, biomedical engineering, pharmaceutical industry and environment. Several broader areas of applications of recombinant DNA technology have been recognized in industry, agricultural, environment and medicine. Several foundational subjects, namely, molecular biology and biophysics have strengthened biotechnology and accelerated its development. Understanding the basic functions of macromolecules is indispensable and can act as a key tool in developing new techniques in several emerging areas of Biotechnology.

This book covers the syllabus of “Basic Biotechnology” paper for M. Sc. Biochemistry prescribed by Bharathidasan University, Tiruchirappalli as Extra Disciplinary Course for their M.Sc., Students. This book attempts to present a simple, understandable text with diagrams for PG students who selected this subject as Extra Disciplinary Course.

In this second edition, the book has been restructured with the incorporation of tables, figures and updated information. It is hoped that this endeavour will continue to be useful to the students.

I express my deep sense of gratitude and record to our Secretary and Correspondent, Principal, Colleagues and students for their encouragement to take up the assignment of writing a text book on Basic Biotechnology for the welfare of the Post-graduate student communities. I hope that the book will be very much useful to students in understanding the subject.

Useful constructive criticisms and suggestions for future improvement of the book are greatly appreciated.

**Authors**

## CONTENTS

<b>1. Fermentation Biotechnology</b>	<b>1</b>
1.1. Basic principles of microbial growth	1
1.2. The bioreactor	1
1.3. Fermenter types	2
1.4. Fermentation culture medium	5
1.5. Downstream processing	7
<b>2. Food and enzyme technology</b>	<b>11</b>
2.1. Biotechnology in food industry	11
2.2. Food fermentation	11
2.3. Fermented foods	13
2.4. Milk products	14
2.5. Immobilised cells	15
2.6. Immobilised enzymes	17
2.7. Methods of immobilisation	17
2.8. Properties of immobilisation enzymes	19
2.9. Applications of immobilisation enzymes	20
<b>3. Energy and Environmental Biotechnology</b>	<b>22</b>
3.1. Biological fuel generation	22
3.2. Ethanol from biomass	23
3.3. Methane from biomass	26
3.4. Waste water treatment	29
3.5. Sewage treatment	30
3.6. Bioremediation	31
3.7. Oil spill clean up	34
3.8. Microbial mining	36
<b>4. Plant and Animal Biotechnology</b>	<b>42</b>
4.1. Applications of DNA technology in agriculture	42
4.2. Applications of DNA technology in animal husbandry	45
4.3. Development of transgenic plants	48
4.4. Development of transgenic animals	52
4.5. Basic principles and applications.	55
4.6. The human genome project	59
<b>5. Analytical Techniques</b>	<b>64</b>
5.1. Radioisotope techniques	64
5.2. Application of radioisotopes in biological sciences	69
5.3. Autoradiography	72
5.4. Spectroscopic techniques	74
5.5. General principles of visible and ultraviolet spectrophotometry	75
<b>Model Questions</b>	<b>80</b>

## 1. FERMENTATION BIOTECHNOLOGY

- 1.1. Basic Principles of Microbial Growth
- 1.2. Bioreactors
- 1.3. Fermenter Types
- 1.4. Fermentation Culture Medium
- 1.5. Downstream Processing

**Fermentation technology** deals with the industrial applications of some microorganisms in the production of some valuable fermentation products. **Fermentation** is an “anaerobic breakdown of complex organic materials by the action of anaerobic microorganisms or by the action of free enzymes”.

### 1.1. BASIC PRINCIPLES OF MICROBIAL GROWTH

The success of fermentation to produce biomass and products depends upon the defined environmental conditions that exist inside the fermentor. Therefore, temperature, pH, agitation, oxygen concentration, etc. should be maintained during the process through careful monitoring of the fermentation. Microbial growth is significantly influenced by pH of the medium and temperature. Bacteria prefer neutral medium *i.e.* pH=7, while acidic pH favours the growth of yeast and fungi. Therefore, pH of the growth medium should be maintained before autoclaving as required by the microbes to be used in fermentor. During the process, suitable temperature of the medium should also be maintained, for example, psychrophiles at 5-15° C, mesophiles at 15-35° C and thermophiles at 45-65° C.

### 1.2. BIOREACTORS

Bioreactors (fermenters) are large-sized vessels that provide a controlled environment for the mass culture of process organisms or their products (Fig. 1). Most of the fermentation reactions are carried out in bioreactors. The **designing of bioreactors** is one of the vital steps in the fermentation production of some products.

#### Fermenter Construction

Starbury and Whitaker (1984) suggested certain ideas for the construction of bioreactors. According to them, an ideal bioreactor must have the following salient features:

1. The fermenter must have continuous working capacity for a long time.
2. It must be larger.
3. It must have a system for providing proper aeration to the culture.
4. It must have a system for giving agitation to the culture.
5. It must have optimal mixing with low, uniform shear.
6. It must have a temperature – regulating device.
7. It must have system for checking and regulating the pH of the fermentable medium during the culture.
8. It must have adequate mass transfer of oxygen.
9. It must have the capacity to do work by consuming less energy.
10. It must have a sampling device.
11. It must avoid the loss.
12. It must have long term stability; compatibility with up- downstream processes.

A fermenter or bioreactor is a container designed to provide an optimum environment in which microorganisms or enzymes can interact with a substrate and form the desired products.

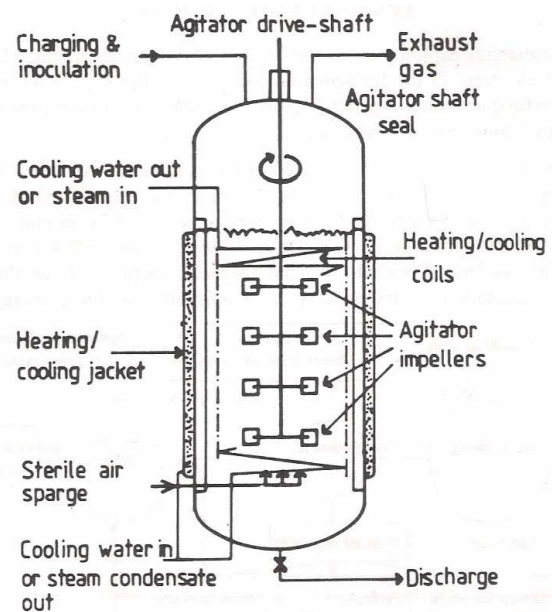

Fig. 1. Diagram of Fermenter.

During fermentation, it is necessary to regulate many factors within predetermined values such as oxygen, carbon dioxide pH, temperature, media concentration, etc. It is also essential to maintain high degree of sterility within fermenter.

The fermenter should be made of stainless steel or copper because such fermenter is resistant to steam sterilization. Chemical processes are carried out in a fermenter using organisms or biochemically active substances derived from such organisms. Bioreactors are at the heart of the fermentation process. These reactors are used for growing cells and chemical production.

### 1.3. FERMENTER TYPES

There are many types of fermenters. The following are the important types of fermenters:

#### Open type fermenter

It allows continuous processing with substrate entering at one end and products leaving at another.

#### Closed type fermenter

In this type, the processing is done in the batches. This type of fermenters is used for the production of antibiotics. Figure represents a typical fermentation vessel. The vessel is cooled by a water jacket. Air is pumped into bottom of the liquid and acid or alkali added as necessary. A stirrer keeps the contents will mixed. Stream lines are provided so that the vessel can be sterilized after each fermentation batch.

#### Stirred tank Bioreactor (STB)

Microbial fermentations received prominence during 1940's namely for the production of life saving antibiotics. Stirred tank reactor is the choice for many (more than 70%) though it is not the best.

**Design of STB:** The stirred tank fermenter is commonly used to carry out fermentation reaction. It is an upright cylindrical vessel (Fig.1). Both the ends of the vessel are closed with hemi-spherical basins. A stirrer properly mixes the air and the nutrients during fermentation. At a lateral side of the fermenter there is an opening through which culture medium is being pumped into the opening is the outlet for harvesting the products. Sterile air is pumped into the fermenter through a pipeline found just below the stirrer. A heating coil is used for raising the temperature inside the vessel. This vessel is covered with a water jacket which has two opening; through one opening, water is pumped into the jacket and the other opening is used to release the water from the jacket. This system is used to reduce the temperature inside the vessel. The upper portion of this vessel has two openings; one of them is used to add inoculum into the fermenter and the other opening is used to release gases produced during fermentation process.

STB's have the following functions: homogenization, suspension of solids, dispersion of gas-liquid mixtures, aeration of liquid and heat exchange. The STB is provided with a baffle and a rotating stirrer is attached either at the top or at the bottom of the bioreactor.

The conventional fermentation is carried out in a batch mode. Since stirred tank reactors are commonly used for batch processes with slight modifications, these reactors are simple in design and easier to operate. Many of the industrial bioprocesses even today are being carried out in batch reactors though significant developments have taken place in the recent years in reactor design, the industry, still prefers stirred tanks because in case of contamination or any other substandard product formation the loss is minimal. The downtimes are quite large and unsteady state fermentation imposes stress to the microbial cultures due to nutritional limitations. The fed batch mode adopted in the recent years eliminates this limitation. The STBs offer excellent mixing and reasonably good mass transfer rates. The cost of operation is lower and the reactors can be used with a variety of microbial species. Since stirred tank reactor is commonly used in chemical industry the mixing concepts are well developed.

#### Airlift bioreactors (ALB)

Airlift bioreactors (Fig. 2) are generally classified as pneumatic reactors without any mechanical stirring arrangements for mixing. The turbulence caused by the fluid flow ensures adequate mixing of the liquid.

The draft tube is provided in the central section of the reactor. The introduction of the fluid (air/liquid) causes upward motion and results in circulatory flow in the entire reactor. The air/liquid velocities will be low and hence the energy consumption is also low. ALBs can be used for both free and immobilized cells.

There are very few reports on ALBs for metabolite production. The advantages of Airlift reactors are the elimination of attrition effects generally encountered in mechanical agitated reactors. It is ideally suited for aerobic cultures since oxygen mass transfer coefficient are quite high in comparison to stirred tank reactors.

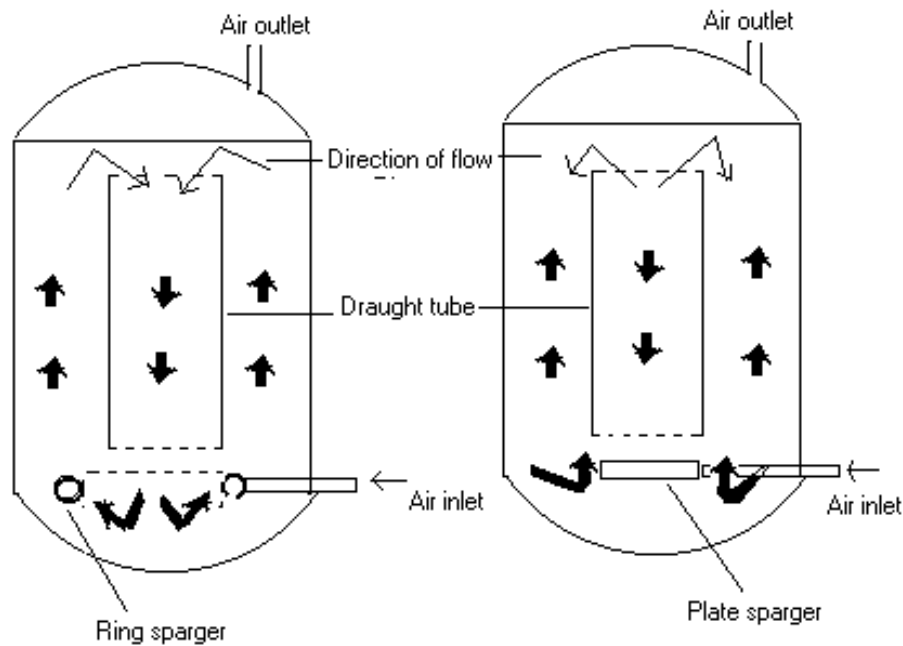

Fig. 2. Airlift bioreactors.

### Fluidized Bed Bioreactors (FBB)

Fluidized bed bioreactors (FBB) have received increased attention in the recent years due to their advantages over other types of reactors. Most of the FBBs (Fig. 3) developed for biological systems involving cells as biocatalysts are three phase systems (solid, liquid & gas). The fundamentals of three phase fluidization phenomena have been comprehensively covered in chemical engineering literature.

The FBBs are generally operated in co-current up flow with liquid as continuous phase and other more unusual configurations like the inverse three phase fluidized bed or gas solid fluidized bed are not of much importance. Usually fluidization is obtained either by external liquid re-circulation or by gas fed to the reactor. In the case of immobilized enzymes the usual situation is of two-phase systems involving solid and liquid but the use of aerobic biocatalyst necessitate introduction of gas (air) as the third phase. A differentiation between the three phase fluidized bed and the airlift bioreactor would be made on the basis that the latter have a physical internal arrangement (draft tube), which provides aerating and non-aerating zones.

The circulatory motion of the liquid is induced due to the draft tube. Basically the particles used in FBBs can be of three different types: (i) inert core on which the biomass is created by cell attachment. (ii) Porous particles in which the biocatalyst is entrapped. (iii) Cell aggregates/ flocs (self-immobilization).

In comparison to conventional mechanically stirred reactors, FBBs provide a much lower attrition of solid particles. The biocatalyst concentration can significantly be higher and washout limitations of free cell systems can be overcome. In comparison to packed bed reactors FBBs can be operated with smaller size particles without the drawbacks of clogging, high liquid pressure drop, channeling and bed compaction. The smaller particle size facilitates higher mass transfer rates and better mixing. The volumetric productivity attained in FBBs is usually higher than in stirred tank and packed bed bioreactors.

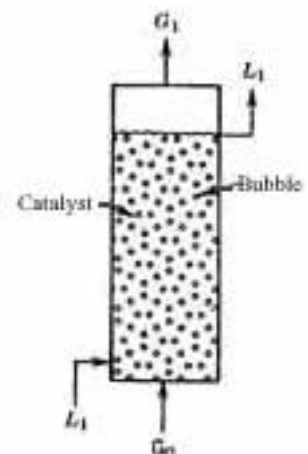

Fig. 3. Fluidized Bed Bioreactor.

### Packed bed bioreactors

Packed bed or fixed bed bioreactors (Fig. 4) are commonly used with attached biofilms especially in wastewater engineering. The use of packed bed reactors gained importance after the potential of whole cell immobilization technique has been demonstrated. The immobilized biocatalyst is packed in the column and fed with nutrients either from top or from bottom.

While working with soft gels like alginates, carragenan, etc. the bed compaction which generally occurs during fermentation results in high pressure drop across the bed. In many cases the bed compaction was so severe that the gel integrity was severely hampered.

In addition channeling may occur due to turbulence in the bed. Though packed beds belong to the class of plug flow reactors in which back mixing is absent in many of the packed beds slight amount of back mixing occurs which changes the characteristics of fermentation. Packed beds are generally used where substrate inhibition governs the rate of reaction. The packed bed reactors are widely used with immobilized cells. Several modifications such as tapered beds to reduce the pressure drop across the length of the reactor, inclined bed, horizontal bed, rotary horizontal reactors have been tried with limited success.

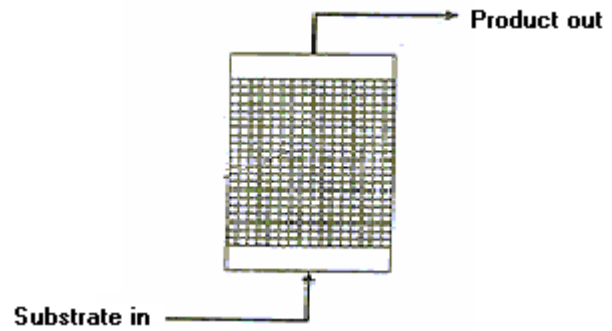

Fig. 4. Packed bed bioreactors.

### Flocculated cell reactors

Flocculated cell reactors (Fig. 5) retain cells by allow them to flocculate. These reactors are used mainly in wastewater treatment.

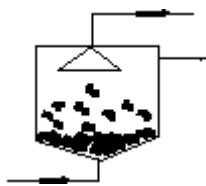

Fig. 5. Flocculated cell reactor.

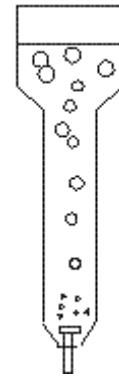

Fig. 6. Bubble column reactors.

### Bubble Column reactors

These are tall reactors (Fig. 6) which use air alone to mix the contents.

## MODES OF BIOREACTOR OPERATION

Bioreactors can be operated in three ways

1. Batch reactors
2. Continuous reactors
3. Fed batch reactors

### 1. Batch reactors

Batch reactors are simplest type of mode of reactor operation. In this mode, the reactor is filled with medium and the fermentation is allowed to proceed. When the fermentation has finished the contents are emptied for downstream processing. The reactor is then cleaned, re-filled, re-inoculated and the fermentation process starts again.

### 2. Continuous reactors

With continuous reactors, fresh media is continuously added and bioreactor fluid is continuously removed. As a result, cells continuously receive fresh medium and products and waste products and cells are continuously removed for processing. The reactor can thus be operated for long periods of time without having to be shut down. Continuous reactors can be many times more productive than batch reactors. This is partly due to the fact that the reactor does not have to be shut down as regularly and also due to the fact that the growth rate of the bacteria in the reactor can be more easily controlled and optimized.

In addition, cells can also be immobilized in continuous reactors, to prevent their removal and thus further increase the productivity of these reactors. Continuous reactors are as yet not widely used in industry but do find major application in wastewater treatment.

### Fed batch reactors

The fed batch reactor is the most common type of reactor used in industry. In this reactor, fresh media is continuous or sometimes periodically added to the bioreactor but unlike a continuous reactor, there is no continuous removal. The fermenter is emptied or partially emptied when reactor is full or fermentation is finished. As with the continuous reactor, it is possible to achieve high productivities due to the fact that the growth rate of the cells can be optimized by controlling the flow rate of the feed entering the reactor.

## 1.4. FERMENTATION CULTURE MEDIUM

### (Development of Culture Medium (or) Operation of Bioreactor (or) Process of Fermentation (or) Up Stream Process)

A proper medium should be formulated for culturing the microbes in the fermenter. The concentration of different constituents in the medium depends upon the specific group of organisms which are to be cultured in the fermenter. A fermentation processes in a bioreactor has upstream and down stream process. All the operations before starting the fermentations are collectively called as **upstream processes**. Microbes are cultured in this process. The technique of microbial culture is a multi-step process and requires media formulation, sterilization, environmental control and operation of bioreactor, culture of the microbial strain, etc. These steps are discussed in this section.

#### Formulation of Medium

A proper medium should be formulated for culturing the microbes in the fermenter. The concentration of different constituents in the medium depends upon the specific group of organisms which are to be cultured in the fermenter. In general, all microbes require at least a carbon source, a nitrogen source, mineral elements, vitamins and one or a few amino acids for their successful growth. The different compounds used in the culture medium are the following:

#### Growth media

Micro-organisms require several nutrients (e.g. carbon. nitrogen. phosphorus. minerals) and oxygen for growth and yield. The nutrient formulations which support optimum microbial growth and yield are called growth medial. On the basis of purity of chemical compounds used, media are grouped into the following three types

**Synthetic media:** Microbes are cultured on a small scale in laboratory on artificially devised nutrient media by using pure chemicals. Such media are called synthetic media such as Czapek Dox agar medium for isolation of fungi.

**Semi-synthetic media:** The media which contain pure forin of chemicals as well as complex compounds are called semi-synthetic media: for example nutrient broth, brain heart infusion broth, etc. In these media the complex compounds are beef extract, yeast extract, peptone, potato or casein digest. Now these media are commercially available.

**Natural media:** The media prepared by using the natural complex ompounds are called natural media soyabean, extract broth, VS juice broth, soil extract broth. etc.

These media are suitable for growth of micro-organisms in laboratory only. However, these are not used on a large scale because these are not economical. Such media are formulated for useon a large scale that are economical and of consistent quality, and available throughout the year. Besides, the raw materials are also pre-treated before use if desired. The following carbon and nitro-en sources used in media for mutation are cheaper, economical and available throughout the year.

#### Sources of nutrition

There are different sources of nutrients required by different types of microorganisms. These are given below.

**Carbon Source:** The carbon sources used for larae scale microbial culture in fermentor are sugarcane molasses, beet molasses, veaetable oil, starch, cereal grains, sucrose. lactose, malt, hydrocarbon, etc. These are the cheap raw materials and used as carbon sources.

**Nitrogen sources:** Ammonium salts, ammonium nitrate, ferrous granules, soybeans meat, yeast extracts, etc. are used as nitrogen sources.

**Mineral elements:** Microorganisms also require certain trace elements (e.g. Calcium, Potassium, Sulphur, Phosphorus, Zinc, Copper, Magnesium, Manganese Zn, Mn, Mo, Cu, Co, etc.) in trace amount. The trace elements are associated with stimulation of metabolism or enzymes (metallo-enzymes) and proteins (leghaemoglobin).

**Buffering Agent:** Sometimes buffering agents are also added to the medium for maintaining its pH.

**Growth Factors:** Some growth substances are also being added to the medium. These growth substances are also being added to the medium. These growth substances increase the rate of the production of desired chemicals. For example the proteins present in the medium increase the production of pectinase.

**pH:** The pH of the medium adjusted to 6-8.

**Water:** Water is the most important component of the living cells. Because of all metabolic activities occur in cytosol. Water-soluble ionic forms of nutrients are absorbed by the cell. In laboratory single or double distilled water is used for preparation of culture media. But for large stage industrial production clean water of consistent composition is required. Dissolved chemicals and pH water are measured. Water is also needed for ancillary activities for example, cleaning, washing, rinsing, cooling heating, etc.

### **Sterilization of medium**

The freshly prepared medium may have a number of unwanted microorganisms in it. These organisms can be inactivated by sterilizing the medium under steam pressure. This method is also called moist-heat sterilization. The moist heat destroys the existing organisms in the medium.

### **Isolation and Selection of Microorganisms**

The culture of process organisms is an essential step in the establishment of fermentation in industries. A wide variety of micro organisms has the property of producing some specific compounds in the medium. Such microbes are isolated from the pool of microbes found in a culture. Any kind of microorganisms which are having the capacity to produce specific substances are isolated for further selection.

After the isolation of the right group of microbes, the specific strain of microbe which produces a large amount of products is selected by using biochemical methods. For example, *Penicillium*, a fungus selected from the mass culture of organisms on an agarised nutrient medium. *Penicillium* produces antibiotics which will kill the bacteria. Those microbes that produce clear zones around them selves are selected and transferred to a fresh medium for further culture. This technique is unique in the selection of microbes which are having the ability to produce antibiotics.

Some times the isolated microbes are serially diluted and plated on agarised medium. The culture plates are incubated at 25 to 35°C. During the incubation, the individual cells develop into colonies. Each colony is then aseptically transferred to the fresh medium and incubated for a few days. Because of incubation, new colonies are formed. Each colony so formed is then tested biochemically to detect the presence of the specific substance in it. The strains are selected for producing stock culture.

### **Production of Stock Culture**

The strain of microbes can be cultured for producing a large number of cells. This culture is used to bring about fermentation reaction in industries. So this culture is called *stock culture*. Usually, stock culture is carried out by means of agar slant method or the streak culture method. For the industrial fermentation process, small-sized bioreactors are used to establish the stock cultures.

### **Inoculum Development**

The microbes present in the stock culture can be multiplied by sub-culturing them in a small fermenter. The fermenter having the capacity to hold 3000-10,000 liters of medium is used for this purpose. In the fermenter, they are cultured for about one month.

Then microbial cells are transferred to seed tanks for establishing the fermentation reaction.

### **Control of Environmental Conditions for Microbial Growth**

The success of fermentation to produce biomass and products depends upon the defined environmental conditions that exist inside the fermentor. Therefore, temperature, pH, agitation, oxygen concentration, etc. should be maintained during the process through careful monitoring of the fermentation. Microbial growth is significantly influenced by pH of the medium and temperature. Bacteria prefer neutral pH, while acidic pH favours the growth of yeast and fungi. Therefore, pH of the growth medium should be maintained before autoclaving as required by the microbe to be used in fermentor. During the process, suitable temperature of the medium should also be maintained, for example, psychrophiles at 5-15°C, mesophiles at 15-35°C and thermophiles at 45-65°C.

### **Aeration and Mixing**

Aeration and mixing are done in laboratory by keeping the flasks on shakers. Hence, it is called shake culture. On the other hand, in large sized fermentors the oxygen should be well mixed and dispersed in the medium, so that it may be available to microbial cells. Therefore, the fermentors are equipped with stirrers for oxygen mixing and baffles for increasing turbulence. Thus adequate mixing is done by the stirrers and baffles. Sufficient mixing and oxygen requirement are also met out through forced aeration. The oxygen molecules come in the contact of cells and diffused inside the cell wall.

## Culture of Microorganisms in the Bioreactor

Before beginning to culture the microbes in a bioreactor or fermenter, the fermenter should be sterilized properly. During the sterilization, microbial contaminants are inactivated by the disinfectant chemicals. Usually, mercuric chloride, silver nitrate, phenolic compounds, ethyl alcohol, halogen like chlorine compounds and iodine compounds are used as disinfectants for sterilizing the fermenter. After proper sterilization, the fermenter must be washed properly with sterile water in order to remove the toxic effect of the disinfectants from it.

The sterilized liquid medium is pumped into the fermenter through an inlet found at its top. The prepared inoculum is inoculated into the fermenter. The  $O_2$  level is properly adjusted by supplying enough amount of  $O_2$  in the fermenter. The temperature is adjusted to get the optimum growth of the process organism. The pH is properly regulated in the culture for establishing the better growth of the organism.

In some cultures, the product of the microorganisms may inhibit their growth, here batch culture mode of operation is followed. In some cultures, the products of microbes does not have any inhibitive effect on them, here continuous mode of operation is followed.

### 1.5. DOWN STREAM PROCESSING (PRODUCT RECOVERY PROCESSING)

When fermentation is over, the desired microbial product is recovered from the growth medium. Then the product is purified, processed, and packed with equal efficiency and economy Product recovery and purification is called **downstream processing**. The technology associated with downstream processing is as important as technology-associated with the fermentation process itself. The operation of any fermentation production process integrates both the technologies. Operation of downstream processing are summarized in Fig. 7.

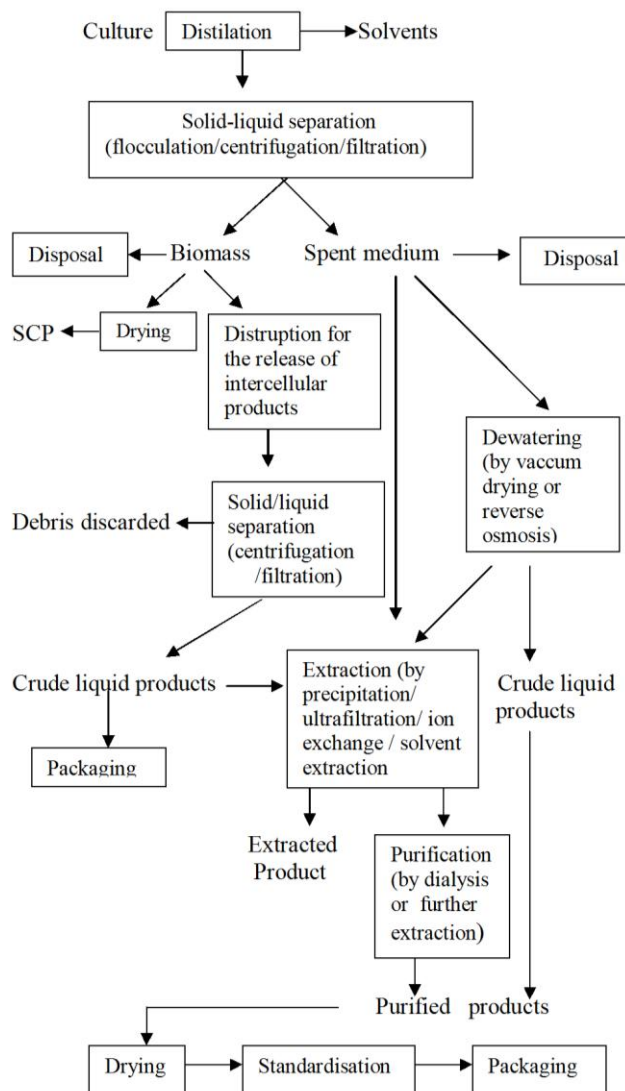

Fig. 7. Stage in down stream processing.

The volatile products can be separated by distillation of the harvested culture without pre-treatment. Distillation is done at reduced pressure at continuous stills. At reduced pressure, distillation of product directly from fermentor may be possible (as done for isolation of ethanol). The steps of downstream processing are as below

**Separation of biomass:** Usually the biomass (microbial cells) is separated from the culture medium (spent medium). If the product is biomass (single cell protein or vaccines), then it is recovered for processing. The spent medium is discarded. Generally, cell mass is separated from the fermented broth by centrifugation or ultracentrifugation. When there is no aeration and agitation, some of the microbial cells soon settle down in the fermentor.

Upon addition of flocculating agents, settling may be more faster. For centrifugation process, settling of microbial cells is necessary. Otherwise, biomass separation may be affected. Ultrafiltration, continuous centrifugation or continuous filtration (e.g. rotatory vacuum filtration) is an alternative to the centrifugation. When a solution is passed through a membrane of 0.5 mm pore size, the particles having size more than the solvent are retained onto it. Using ultrafiltration fermented broth you can separate microbial cells from fermented broth.

**Cell disruption:** If the desired product is intracellular (e.g. vitamins, some enzymes and recombinant proteins like human insulin) the cell biomass can be disrupted so that the product should be released. The solid-liquid is separated by centrifugation or filtration and cell debris are discarded.

**Concentration of broth:** The spent medium is concentrated if the product is extracellular.

**Initial purification of metabolites:** There are several methods for recovery of product from the clarified fermented broth e.g. precipitation, solvent extraction, ultra-filtration, ion-exchange chromatography, adsorption and solvent extraction. The extraction procedure vary according to physico-chemical nature of the molecules of products, and preference of the manufacturers. A step of isolation of extra cellular microbial metabolite (such as antibiotic, penicillin which is secreted in broth) is given in Fig. 8.

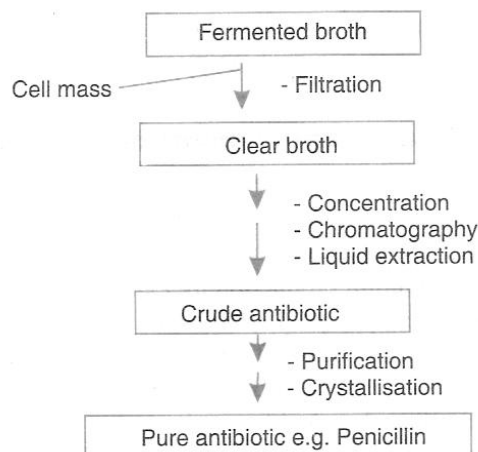

Fig. 8. Isolation of extra cellular microbial product (e.g. penicillin from *Penicillium chrysogenum*).

**Metabolite-specific purification:** Specific methods are used when the desired metabolite is purified to a very high degree.

**De-watering:** When a low amount of product is found in very large volume of spent medium, the volume is reduced by removing water to concentrate the product. It is done by vacuum driving or reverse osmosis. This process is called de-watering.

**Final purification of metabolites:** It is the final step of making the product to 98-100% pure. The products may be marked in aqueous form or in the solid form; these products must be stored in cool places before marketing. The purity of the products depends upon the successful operation of the down stream processes. The purified product is mixed with several cheaper inert ingredients called **excipients**. The formulated product is packed and sent to the market for the consumers.

## Fermentation Products

The fermentation processes result in the production of a wide class of organic compounds, such as amino acids, proteins, enzymes, organic acids, antibiotics, polysaccharides, single-cell proteins, etc. The important fermentation products are given below:

### Production of Amino Acids

Different kinds of organisms have the property of producing amino acids in the culture medium. This property of microbes is used in industries to produce amino acids.

### Production of Alcohols

Alcohols are produced during the fermentation effected by bacteria. The microbes produce ethanol, methanol, and butanol in the medium. Chatin Weizmann stated that *Bacillus granulobacter* produces alcohols in the medium containing diluted corn-starch solution. *B.granulobacter* produces butanol, acetone and ethanol in the ratio 6:3:1. D. I. Wang used *Closteridium thermocellum* and *C. thermosaccharolyticum* for producing ethanol from cellulose and sugars. The former degrades cellulose into simple sugars, while the later converts sugars into ethanol.

### Production of Organic Acids

Different groups of organisms produce organic acids in the culture during their growth. Some important organic acids and corresponding process organisms are listed in the following table.1.

Table 1. Some microbes and organic acids.

S.No.	Name of the organic acid	Name of the process organism
1	Aconitic acid	<i>Aspergillus itaconicus</i>
2.	Citric acid	<i>A.niger, Penicillium citratium</i>
3.	Glycolic acid	<i>Aspergillus niger</i>
4	Lactic acid	<i>Lactobacillus, Streptococcus lactis, Mucor, Rhizopus, etc.</i>
5.	Malic acid	<i>A Fumericus, A.niger</i>
6	Oxalic acid	<i>A.niger</i>
7	Succinic acid	<i>Rhizopus, Mucor, Fusarium,</i>

### Production of Antibiotics

A wide class of fungi and bacteria produce antibiotics in the culture The different process organisms and their products are given in the table 2.

Table 2. Some microorganisms and antibiotics.

S. No.	Name of antibiotics	Process organism
1	Cephalosporin	<i>Cephalosporium. sps.</i>
2	Chloroamphenical	<i>Streptomyces venezuelae</i>
3	Penicillin-G	<i>Penicillium chryzogenum and Aspergillius niger</i>
4	Rifamycin	<i>Nocardia mediternea</i>
5	Tetracyclin	<i>Streptomyces rimosus</i>
6	Cloromycetin	<i>S. venezuelae</i>

### Production of Alcoholic Beverages.

A number of beverages like wine, vinegar, beer, brandy, whiskey, rum, etc. are produced by fermentation. Production of beverages is a purely microbial process. Some important process organisms and their products are given in the table 3.

Table 3. Some organisms and their products.

S.No.	Source	Name of the process organism	Products
1.	Ripe grape juice	<i>Saccharomyces ellipsoideus</i>	Wine
2.	Marsh grain of corn	<i>Saccharomyces cerevisiae</i>	Whiskey
3	Grape juice, Peach, Apple, Orange	<i>Saccharomyces cerevisiae</i>	Brandy
4	Malt extract	<i>Saccharomyces cerevisiae</i>	Malt beverage
5	Cane molasses or beet molasses	<i>Closteridium saccharobutyricum</i>	Rum

### SHORT QUESTIONS

1. Fermentation technology
2. Microbial growth
3. Bioreactor
4. Fermentation
5. Downstream processing
6. Upstream processes
7. Growth media
8. Semi-synthetic media
9. Sterilization
10. Bioreactors
11. Open type fermenter
12. Closed type fermenter
13. Enzyme reactors
14. Upstream processes

### QUESTIONS

1. Write the basic principles of microbial growth.
2. Discuss the different types of bioreactor.
3. Explain the extraction method of fermented products.
4. Describe the Fermentation culture medium.
5. Explain the fermenter construction.
6. Give an account on downstream processing.
7. What is fermentation? Give an illustrated account of design and functioning of a fermenter.
8. Give a detailed account of formulation of growth medium and fermentation process of Penicillin.

## 2. FOOD AND ENZYME TECHNOLOGY

### 2.1. Biotechnology in Food Industry

#### 2.2. Food Fermentation

#### 2.3. Fermented Foods

#### 2.4. Milk Products

#### 2.5. Immobilized Cells

#### 2.6. Immobilized Enzymes

#### 2.7. Methods of Immobilization

#### 2.8. Properties of Immobilization

#### 2.9. Applications of Immobilization

### 2.1. BIOTECHNOLOGY IN FOOD INDUSTRY

Biotechnology has been used to manufacture food products for more than 8,000 years. Bread, alcoholic beverages, vinegar, cheese and yogurt, and many other foods owe their existence to enzymes found in various microorganisms. Biotechnology in food industry is concerned with application of physical, chemical, and biological sciences to food processing and preservation, and to the development of new and improved food products. Today's biotechnology will continue to affect the food industry by providing new products, lowering costs and improving the microbial processes on which food producers have long relied.

Food technology is a multidisciplinary science subject, involving chemistry, biochemistry, microbiology, physics, process engineering, and industrial management. Food scientists and technologists are responsible for ensuring that food items produced are safe, nutritious, and of the quality and substance demanded by the consumer. Everyone needs to eat, so there will be a continuing demand for food technologists.

As part of the National Curriculum in British schools, food technology can be defined as "using knowledge and skills to design and make good quality food products". Essential skills and knowledge for food technology include learning about ingredients, food products, and nutrition, using tools and equipment accurately and hygienically, understanding systems and control, designing and adapting recipes, creating product specifications, carrying out sensory evaluation, and knowing about industrial practice. Food technology within the curriculum is different to home economics since it focuses on the industrial knowledge of making food products, and less on preparing family meals, looking after children, and consumer studies. Within the design and technology curriculum, pupils may study food safety and microbiology.

### 2.2. FOOD FERMENTATION

Food fermentation is a process by which a food goes through a chemical change caused by enzymes produced from bacteria, microorganisms or yeasts. Fermentation alters the appearance and or flavor of foods and beverages such as beer, buttermilk, cheese, wine, vinegar and yogurt.

Food fermentation covers a wide range of microbial and enzymatic processing of food and ingredients to achieve desirable characteristics such as prolonged shelf-life, improved safety, attractive flavour, nutritional enrichment and promotion of health. Major fermentation microorganisms include lactic acid bacteria, moulds and yeasts.

Fermented foods are popular throughout the world and in some regions make a significant contribution to the diet of millions of individuals. For instance Soy sauce is consumed throughout the world and is a fundamental ingredient in diets from Indonesia to Japan. Over one billion litres of soy sauce are produced each year in Japan alone. In Africa fermented cassava products (like gari and fufu) are a major component of the diet of more than 800 million people and in some areas these products constitute over 50% of the diet. Fermentation is a relatively efficient, low energy preservation process, which increases the shelf life and decreases the need for refrigeration or other forms of food preservation technology. It is therefore a highly appropriate technique for use in developing countries and remote areas where access to sophisticated equipment is limited. There is tremendous scope and potential for the use of microorganisms towards meeting the growing world demand for food, through efficient utilisation of available natural food and feed stocks and the transformation of waste materials.

## Organisms Responsible for Food Fermentations

The most common groups of microorganisms involved in food fermentations are:

1. **Bacteria**
2. **Yeasts**
3. **Moulds**

### Bacteria

Several bacterial families are present in foods, the majority of which are concerned with food spoilage. As a result, the important role of bacteria in the fermentation of foods is often overlooked. The most important bacteria in desirable food fermentations are the Lactobacillaceae which have the ability to produce lactic acid from carbohydrates. Other important bacteria, especially in the fermentation of fruits and vegetables, are the acetic acid producing Acetobacter species.

### Yeasts

Yeasts and yeast-like fungi are widely distributed in nature. They are present in orchards and vineyards, in the air, the soil and in the intestinal tract of animals. Like bacteria and moulds, yeasts can have beneficial and non-beneficial effects in foods. The most beneficial yeasts in terms of desirable food fermentation are from the Saccharomyces family, especially *S. cerevisiae*. Yeasts are unicellular organisms that reproduce asexually by budding. In general, yeasts are larger than most bacteria. Yeasts play an important role in the food industry as they produce enzymes that favour desirable chemical reactions such as the leavening of bread and the production of alcohol and invert sugar.

### Moulds

Moulds are also important organisms in the food industry, both as spoilers and preservers of foods. Certain moulds produce undesirable toxins and contribute to the spoilage of foods. The *Aspergillus* species are often responsible for undesirable changes in foods. These moulds are frequently found in foods and can tolerate high concentrations of salt and sugar. However, others impart characteristic flavours to foods and others produce enzymes, such as amylase for bread making. Moulds from the genus *Penicillium* are associated with the ripening and flavour of cheeses. Moulds are aerobic and therefore require oxygen for growth. They also have the greatest array of enzymes, and can colonise and grow on most types of food. Moulds do not play a significant role in the desirable fermentation of fruit and vegetable products.

When microorganisms metabolise and grow they release by-products. In food fermentations the by-products play a beneficial role in preserving and changing the texture and flavour of the food substrate. For example, acetic acid is the by-product of the fermentations of some fruits. This acid not only affects the flavour of the final product, but more importantly has a preservative effect on the food. For food fermentations, micro-organisms are often classified according to these by-products. The fermentation of milk to yoghurt involves a specific group of bacteria called the lactic acid bacteria (*Lactobacillus* species). This is a general name attributed to those bacteria which produce lactic acid as they grow. Acidic foods are less susceptible to spoilage than neutral or alkaline foods and hence the acid helps to preserve the product. Fermentations also result in a change in texture. In the case of milk, the acid causes the precipitation of milk protein to a solid curd.

### Conditions Necessary for Food Fermentation

Most yeast require an abundance of oxygen for growth, therefore by controlling the supply of oxygen, their growth can be checked. In addition to oxygen, they require a basic substrate such as sugar. Some yeast can ferment sugars to alcohol and carbon dioxide in the absence of air but require oxygen for growth. They produce ethyl alcohol and carbon dioxide from simple sugars such as glucose and fructose.

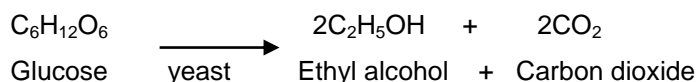

In conditions of excess oxygen (and in the presence of *Acetobacter*) the alcohol can be oxidised to form acetic acid. This is undesirable if the end product is a fruit alcohol, but is a technique employed for the production of fruit vinegars

Yeasts are active in a very broad temperature range from 0 to 50° C, with an optimum temperature range of 20° to 30° C. The optimum pH for most micro-organisms is near the neutral point (pH 7.0). Moulds and yeasts are usually acid tolerant and are therefore associated with the spoilage of acidic foods. Yeasts can grow in a pH range of 4 to 4.5 and moulds can grow from pH 2 to 8.5, but favour an acid pH

In terms of water requirements, yeasts are intermediate between bacteria and moulds. Bacteria have the highest demands for water, while moulds have the least need. Normal yeasts require a minimum water activity of 0.85 or a relative humidity of 88 %.

Yeasts are fairly tolerant of high concentrations of sugar and grow well in solutions containing 40 % sugar. At concentrations higher than this, only a certain group of yeasts – the osmophilic type can survive. There are only a few yeasts that can tolerate sugar concentrations of 65-70 % and these grow very slowly in these conditions. Some yeast – for example the *Debaromyces* can tolerate high salt concentrations. Another group which can tolerate high salt concentrations and low water activity is *Zygosaccharomyces rouxii*, which is associated with fermentations in which salting is an integral part of the process.

### 2.3. FERMENTED FOODS

Many products are produced by bacterial fermentations. These include the fruit and vegetable pickles produced by lactic acid fermentation and the products of alkaline bacterial fermentations. Lactic acid bacteria pickling is still carried out at the domestic scale.

#### Ice Cream

Another success of food technology came with ice cream. This popular foodstuff, thousands of years old, is produced from an oil-in-water emulsion, which is partially destabilized during freezing, to give some fat-clumping, which helps in giving a smoother texture. Today, emulsifiers and stabilizers are used to help keep some of the aqueous phase from freezing, preventing graininess in texture. Freeze-drying is a useful process in which foods are frozen and then held in a vacuum with the ice being removed by converting it directly into vapour (sublimation). It is used where the expense of the process can be justified by the benefits it provides in retaining good flavour and convenience, as, for example, in freeze-dried instant coffee.

#### Single Cell Protein

The phrase "Single cell Protein (SCP)" was introduced for the first time in the 1960's to refer to the microbial proteins produced by yeasts, bacteria, cyanobacteria, fungi and algae and useful as human food or animal feed.

Production of microbial proteins: Several workers and public enterprises seriously explored the possibility of extracting SCP from microbes grown on hydrocarbons. The production of microbial proteins (SCP) has been practiced since First World War when Delbruck in Berlin, developed brewer's yeast on a large scale. The cells were mainly incorporated into soups and sausages. Even during the Second World War, food yeasts including *Candida arborea* and *Candida utilis* had been frequently used in Germany.

**Chlorella:** The development of the Chlorella health food industry in the early 1960s was based largely on plants of a circular pond design with large mixing arms. By the 1970's most new algae production units used the raceway pond design as developed by Oswald at the University of California, Berkeley. These were mixed by paddlewheels like other systems for *Dunaliella* and *Spirulina* production. Pond sizes are typically about 0.4-0.5 ha for most commercial systems.

**Nutrients:** Besides proteins, these microbial cells are also rich in carbohydrates, fats, vitamins and minerals. SCP is a potential protein source food for humans or animals. At present, SCP processes for the production of animal feed are the most attractive, since conventional animal feed stuffs such as soybean meal and fish meal as being imported to many tropical and subtropical countries at the present international prices. In using SCP for animal feed, however, there is a huge loss of conversion efficiency as opposed to direct human use. For human use, microbes used are primarily *Saccharomyces cerevisiae* and *Candida utilis* and are fully accepted by public health authorities for human consumption. If these organisms are used as a major protein diet source, they need be processed further to minimise the nucleic acid content, to avoid the formation of kidney stones or gout.

Thousands of kinds of fermented foods are being produced industrially in Japan, Korea, China and other oriental countries. Miso, shoyu, ontjam kimchi, beer, tempeh, and fermented fish and meat are good examples. Fermentation often makes the food more nutritious, more digestible, safer, or having better flavour. It also tends to preserve the food, increasing its shelf life and lowering the need for refrigeration.

Fermentation can be applied to all kinds of foods. Eight classes of fermented food may be recognised viz. beverages, cereal products dairy products, fish products, fruit and vegetable products legumes meat products and starchy products of their dairy products cereal products and beverages are the most common.

Beer is produced from cereal grains which have been malted dried and ground into fine power. The powder is washed in warm water. Fermentation of the washed power is mediated either by bottom yeast (e.g. *Saccharomyces uvarum*) or by top yeast (*S. cerevisiae*). The final product (beer) has up to about 8%

alcohol. Grapes can be directly fermented by yeasts to wine. Wine is made by distillation of the alcoholic broth formed by fermentation of grape juice.

### Production of Fermented Enzymes by Microorganisms

The following are the microorganisms, which produces enzymes used in Food Industries by fermentation: Dried bonito,soyasauce (*Aspergillus oryzae*, *Pediococcus soyae*, *Saccharomyces rouxii*, *Torulopsis spp.*), vinegar (*Gluconobacter suboxidans*), pickled vegetables, cheeses (*Penicillium camembertii*, *P. roqueforti*, *Propionibacterium shermanii*, *Streptococcus spp.*) and yoghurt, lactic acid (sour) drinks (*Lactobacillus bulggricus*, *Streptococcus thermophilus*).

### Alcoholic Fermentation

Bear (*Saccharomyces cerevisiae*, *S. carlsbergensis*, *S. uvarum*), cider (*S. cidri*), wine (*S. cerevisiae*), sake (*Aspergillus oryzae*, *Lactobacillus* and *Leuconostoc spp.*, *S. cerevisiae*) and other fermentations of fruit juices, distilled sprits, etc.

### Vanilla

Vanilla is produced in Madagascar, Indonesia and various South Pacific islands. It is a dark brown pod about 20 cm in length. Vanilla is produced by fermenting the pods of the orchids of the genus vanilla. The pods are first sun dried for 24 to 36 hours and then blanched in hot water (65° C) for two to three minutes. The pods are then fermented in boxes and dried again.

### Tabasco

Tabasco sauce is made in Mexico and Guatemala. The chilli pods are harvested, ground into a paste and placed in a container with salt. The hot and fiery sauce develops.

### Tea

In the production of tea, there is a process referred to as fermentation. However microbial activity is not involved in the so-called 'fermentation' of tea. The chemical changes are effected by enzymes alone. Fermentation rooms are used where moisture and temperature can be controlled. During fermentation even further darkening of the leaf occurs and the typical aroma develops. By subjective judgement of the aroma's intensity the period necessary for completion is gauged.

### Bread

Bread is a simple fermentation of sugar to CO<sub>2</sub> and alcohol. The baker first combines flour, sugar, milk and other ingredients with a microorganism, usually bread yeast such as *Saccharomyces cerevisiae*, but not always. The ingredients are mixed and then allowed to incubate at 27C for a few hours. During this time the yeast convert the sugar present to ethanol and CO<sub>2</sub>. Most incubations are for less than 4 hours not leaving enough time for the yeast to increase in number. The CO<sub>2</sub> produced causes the bread to rise (leaven) and become porous. The success of leavening is dependent upon the rate of gas production. This can be increased by adding more yeast, more sugar, or dough conditioners (various salts that the yeast need). Tweaking a recipe by manipulating these factors can speed CO<sub>2</sub> production, within reasonable limits. Adding too much of anything can either kill the yeast or cause the bread to rise too quickly. The temperature of incubation is another critical consideration. *Saccharomyces* grows best at 26 to 28° C and deviations from that temperature will usually result in slow or complete lack of leavening. Failure as a baker can normally be attributed to either not adding the exact amounts of ingredients or inappropriate incubation temperatures during leavening.

## 2.4. MILK PRODUCTS

**Yogurt:** Yogurt is a product of fermented milk. Lactic acid bacteria are the major microbes in many milk based fermented products. These bacteria are finicky having many growth requirements all of which can fortunately be satisfied by a milk mixture. Lactose in milk is fermented to lactic acid either via the homofermentative or heterofermentative pathway.

Production of yogurt starts by conditioning the milk. The water content of milk is first lowered 25% by vacuum evaporation and 5% milk solids are added. As a final conditioning step, the milk is heated to 86 to 93C for 30-60 minutes. This causes some breakdown of proteins and other molecules and kills contaminating microbes that may compete with the starter culture. After cooling to 45° C a 1:1 mixture of *Streptococcus thermophilus* and *Lactobacillus bulgaricus* is added. Fermentation is at 45° C until the desired degree of acidity is reached. This usually occurs in 3-5 hours. The finished product may have other ingredients added (such as mold inhibitors or dye) and is packages with fruit. Yogurt is stored at 0-4° C until consumed to prevent spoilage.

There is some evidence that consumption of products containing active cultures of lactic acid bacteria can be beneficial. However, the health claims by proponents of this idea have yet to withstand serious scientific scrutiny. It is reasonable to assume that ingesting lactic acid bacteria may help deter other more severe pathogens such as *E. coli* or *Salmonella typhimurium*

**Cheese:** Cheese is also a milk fermentation, but its production is more complex. Different bacteria come into play and production periods are much longer than yogurt. Despite there being 20 classes and hundreds of varieties of cheeses the initial manufacturing process is surprisingly similar.

**Curd Formation:** Milk is first pasteurized and then fermented by a starter culture. This is usually a lactic acid bacteria with the specific species in use dependent upon the cheese being produced. Rennet (protease) is added to the fermentation and along with the lactic acid made by the added starter, causes the milk to form curds.

Curd Concentration depending upon the cheese being made, the curds may be concentrated in some manner. The goal here is to remove the appropriate amount of whey (liquid left from curd formation). For fresh cheeses (cottage or mozzarella) no concentration takes place. Soft cheeses the curds are cut into large cubes and then ripened with a fungus or mold. Hard and semi-hard cheeses are cooked and then cut into small pieces to release more whey.

## 2.4. IMMOBILIZED CELLS

In the field of enzyme technology, immobilisation of whole cells is now a well developed method. Successful performance of several industrial plants has been demonstrated. In cell Immobilisation technology the main important feature is that enzymes are active and stable for a long period of time. It keeps within the cellular domain together with all cell constituents whether the cells are dead or viable but in resting state.

The methods of whole cell immobilization are same as described for enzyme immobilization i.e. adsorption, covalent bonding, cell to cell cross-linking, encapsulation, and entrapment in polymeric network. Since a long time adsorption of cells to preformed carrier has been used for example use of woodchips as carrier for *Acetobacter* has been in practice for vinegar production since 1823. Preformed carrier of ones choice is used (Table 4). Cell attachment to the surface of preformed carrier is done by covalent bonding.

Table 4. Immobilization of whole cells by different method.

Support material	cells	Reaction
<b>Adsorption</b>		
Gelatin	<i>Lactobacilli</i>	Lactose/lactic acid
Porous lass	<i>Saccharom ices</i>	Glucose/ethanol
	<i>Carlsbergensis</i>	
Cotton fibres	<i>Zonoinonas mobilis</i>	Glucose/ethanol
Vermiculite	<i>Z. mobilis</i>	Glucose/ethanol
DEAE-cellulose	<i>Nocardia erithropolis</i>	Steroid conversion
<b>Covalent Bonding</b>		
Cellulose + cyanuric chloride	<i>Seererisicle</i>	Glucose/ethanol
<b>Enzyme Biotechnology</b>		
Ti (IV) oxide. etc.	<i>Acetobacter sp.</i>	Wort/vinegar
Carboxymethylcellulose		
carbodifinide	<i>Bacillus subtilis</i>	L-histidine/uronic acid
<b>Cross-linking of cell-to-cell</b>		
Diazotized diarnines	<i>Streptomyces</i>	Glucose/fructose
Glutaraldehyde	<i>E. coli</i>	Fumaric acid/L
		aspartic acid
Flocculation by chitosan	<i>Lactobacillus brevis</i>	Glucose/fructose

**Entrapment**

Al alzinate	<i>Candida tropicalis</i>	Phenol degradation
Ca alginate	<i>S. cerevisiae</i>	Glucose/ethanol
Mg pectinate	Fungi	Glucose/fructose
K-carrageenan	<i>E. coli</i>	Fumaric acid/L-aspartic acid
Chitosan alginate	<i>S. cerevisiae</i>	Glucose/ethanol

**Encapsulation**

Cellulose acetate	<i>Conianionas sp.</i>	7-ACA production
Ethyl cellulose	<i>Streptomyces sp.</i>	Glucose/fructose
Poly ester	<i>Streptomyces sp.</i>	Glucose/fructose
Alginate-polyksine	Hybridoma cells	Monoclonal antibodies

**Use of Microcarrier Beads in Cell Immobilization**

The properties of microcarrier beads used for cell immobilisation are that they develop charged surfaces, either positive or negative charges, for example. DEAE sephadex (diethyl - amino ethyl type of cross-linked dextran) developed positive charges. polysysteine negative charges, gelatin beads slightly positive or negative charges. The beads require surface coating for adhesion of sufficient number of cells, because energy is required for cell adhesion. In addition glass and ceramic materials are used as good carriers as they contain high surface energy. In different types of bioreactors different materials such as glass spheres are packed for cell attachment. The materials increase surface area for cultivation of cells en masse.

**Process of Cell Immobilization**

Immobilisation of microorganisms to the bedding materials in biofilters consists of following processes: (a) the self-attachment of cells to the filter bedding material, and (b) the artificial immobilisation of microorganisms to the bedding material. Self-attachment of microorganisms to a surface depends on the microbial culture i.e. secretion of glycocalyx (extracellular polysaccharide) and several forces such as electrostatic interaction, covalent bond formation, hydrophobic interaction. and partial covalent bond between microorganisms and hydroxyl groups on surfaces. Immobilisation of microorganisms at filter bedding is done by five methods such as: carrier bonding, cross-linking, entrapment, microcapsulation and membrane methods.

**2.5. IMMOBILIZATION OF ENZYMES**

Free enzymes are protected by inserting them into a semi-solid carrier. This process of arresting the free movement of enzymes is called enzymes immobilization. Such Protected enzymes are often named immobilized enzymes.

The immobilized enzymes have more advantages than the free enzymes. Some important advantages are given below:

1. The immobilized enzymes have more stability than the free enzymes. So the turn over of substrate into products is higher.
2. The immobilized enzymes are firmly attached to the solid materials. So the wastage of enzymes during the extraction of the product is avoided.
3. The reaction potential of the immobilized enzymes is more when compared with that of the free enzymes. So they catalyse the production of maximum amount of products within a unit time.
4. The enzymes produce only desired products with nearly cent percent purity.
5. The solid materials freely allow the substrate to reach the immobilized enzyme.
6. Immobilized enzymes produce cent percent pure products.

The cell-free reaction system behaves as a model system for studying the enzyme action of living cells.

## 2.6. IMMOBILIZED ENZYMES

The changes that occur during fermentation of foods are the result of enzymic activity. Enzymes are protein molecules which serve to accelerate the chemical reactions of living cells (often by several orders of magnitude). Without enzymes, most biochemical reactions would be too slow to even carry out life processes. Enzymes display great specificity and are not permanently modified by their participation in reactions. Since they are not changed during the reactions, it is cost-effective to use them more than once. However, if the enzymes (or cells) are in solution with the reactants and/or products it is difficult to separate them. Therefore, if they can be attached to the reactor in some way, they can be used again after the products have been removed. The term "immobilized" means unable to move or stationary. And that is exactly what an immobilized enzyme (or cells) is: an enzyme (or a cell) that is physically attached to a solid support over which a substrate is passed and converted to product.

In the food industry, enzymes have several roles - the liquefaction and saccharification of starch, the conversion of sugars and the modification of proteins. Microbial enzymes play a role in the fermentation of fruits and vegetables. Enzymes are widely used commercially, for example in the detergent, food and brewing industries. Protease enzymes are used in 'biological' washing powders to speed up the breakdown of proteins in stains like blood and egg. Pectinase is used to produce and clarify fruit juices.

Immobilized enzymes (or cells) are enzymes which are either covalently bound or absorbed onto the surface of an insoluble

support. Immobilized enzymes have several advantages over the soluble enzyme.

### Examples

Amino acylase, Amyloglucosidase, PenicillinG-acylase, protease,  $\alpha$ -amylase and lactase are examples of immobilised enzymes.

### Commercial Advantages

Enzymes can be immobilized by fixing them to a solid surface. This has a number of commercial advantages:

- The enzyme is easily removed.
- The enzyme can be packed into columns and used over a long period.
- Speedy separation of products reduces feedback inhibition.
- Thermal stability is increased allowing higher temperatures to be used.
- Higher operating temperatures increase rate of reaction.

## 2.7. METHODS OF IMMOBILIZATION

The immobilization of enzymes depends on the specific reactions between the enzyme and the carrier. The different methods available for immobilizing the enzymes are given below:

### Physical Adsorption

Physical adsorption of an enzyme onto a solid (Fig.9) is probably the simplest way of preparing immobilized enzymes. The method relies on non-specific physical interaction between the enzyme protein and the surface of the matrix, brought about by mixing a concentrated solution of enzyme with the solid. Generally, polymers are used to immobilize enzymes. Sometimes cellulose based ion exchange resins, porous glass materials, silica gels and charcoals are also used as carriers.



Fig. 9. Physical adsorption.

A major advantage of adsorption as a general method of insolubilizing enzymes is that usually no reagents and only a minimum of activation steps are required. As a result, adsorption is cheap, easily carried out, and tends to be less disruptive to the enzymic protein than chemical means of attachment, the binding being mainly by hydrogen bonds, multiple salt linkages, and Van der Waal's forces.

Amino acylase is adsorbed on DEAB sephadex polymer for immobilization. Amyloglucosidase is adsorbed on charcoal.

### Enzyme Entrapment in Polymer Matrix

Polyacrylamide is a polymer. When it is mixed with an enzyme, it forms a thread like matrix around the enzyme molecules (Fig. 10). This matrix immobilizes the enzyme within the polymer. This immobilization method is called enzyme entrapment. The broad distribution in pore size of synthetic gels of the polyacrylamide type inevitably results in leakage of the entrapped enzyme, even after prolonged washing. This may be overcome by cross-linking the entrapped protein with glutaraldehyde. Alternatively, ultrafiltration membranes of well-defined pore size may be used to occlude the enzyme.

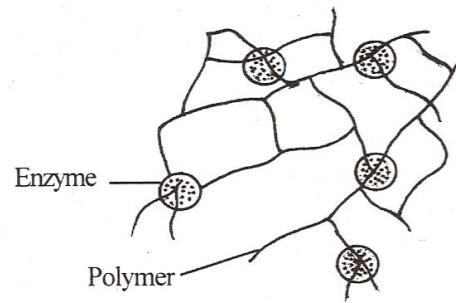
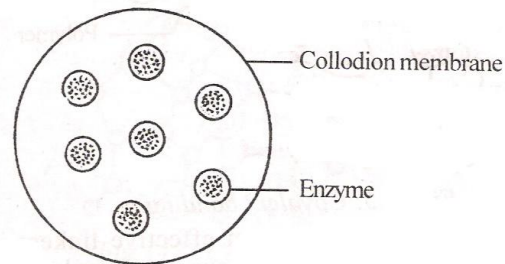

Fig. 10. Enzyme entrapment in polymer matrix.

**3. Encapsulation:** Tais Chang in Canada first adopted this technique for immobilizing enzymes. In this method the enzymes are entrapped in a semi-permeable membrane (Fig. 11). Nylon membrane or collodion membrane is used for the encapsulation of enzymes. The small membrane vesicles containing the enzyme are called microcapsules.



11. Encapsulation of enzyme.

### Liposomal Entrapment

The enzyme and a phospholipid are mixed together in a flask or tube and shaken well to induce enzymes for being inserted into the lipid bodies because of proper mixing. The lipid completely surrounds the enzyme and forms a lipid envelope (Fig. 12). This lipid bodies are called liposomes.

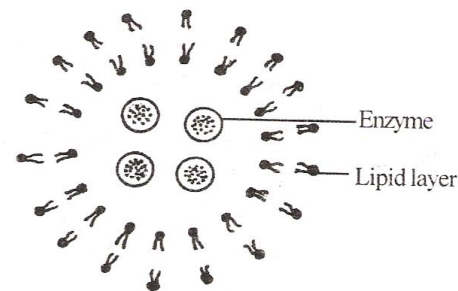

Fig. 12. Liposomal Entrapment.

### Covalent Bonding

The covalent binding method is based on the binding of enzymes and water-insoluble carriers by covalent bonds (Fig. 13). The functional groups that may take part in this binding are listed below:

Amino group, Carboxyl group, Sulfhydryl group, Hydroxyl group, Imidazole group, Phenolic group, Thiol group, Threonine group and Indole group. The groups unavailable for the enzyme reaction only take part in covalent bonding. Penicillin-G-acylase is immobilized in sephadex polymer by co-valent bonding.

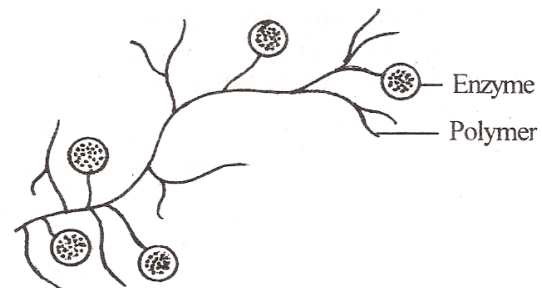

Fig. 13. Covalent bonding.

Synthetic polymers form effective linkers in the immobilization of enzymes. For example, acryl copolymer has aldehyde group, carboxy methyl group and hydrocyanate group. These groups are involved in the establishment of covalent bonds with the enzymes. Sometimes, some small molecules are used as linkers to join the enzymes with the polymers. The linker molecule has two reactive groups. Eg. Cyanuric chloride, glutaraldehyde and cyanogen bromide.

### Co-polymerization

Multifunctional copolymers are often used in the enzyme immobilization. Each polymer connects the enzyme molecules and it connects the other polymers. That is the polymers are inter-connected with one another and also with the enzymes (Fig. 14). Glutaraldehyde is one of the copolymers commonly used in enzyme immobilization. Glucose isomerase is immobilized in cross-linked glutaraldehyde.

## 2.8. PROPERTIES OF ENZYMES

**Presence of Species Specificity:** Macromolecules including proteins differ in different species i.e. they are species specific. It is attributed that the phylogenetic development which has given rise to microbiological variations caused by variation in these molecules. Enzyme types (protease,  $\alpha$ -amylase, lactase) which are found in many species will have properties which vary as much as the other properties of the organisms, for example, protease of two closely related species differs in several ways in spite of some similarities.

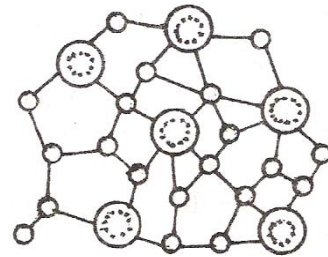

Fig. 14. Co-polymerization

**Variation in Activity and Ability:** Most of microbial enzymes applied in various ways are extracellular in their origin; they are influenced externally by temperature, pH, etc. However, their optimum stability and activity are very much close to optimum conditions for microbial growth. For example, optimum pH is temperature for amylase activity of a thermophilic microbial species i. g. *Bacillus coagulans* differ from that of mesophilic species of some microbe (*B. licheniformis*). Unlike extracellular enzyme, the intracellular enzymes are little influenced by external environmental factors.

Activity and stability of enzymes also differ. Xylose isomerase is stable at pH range from 4.0 to 8.5 but shows optimum activity at pH between 5.5 and 7.0. Similarly, temperature also influences enzyme activity. On increasing the temperature enzyme activity gradually increases, but at certain stages, temperature inactivates the rate of reaction and finally enzyme is denatured (at high temperature) as it is proteinaceous in nature. Thermal stability in the target enzyme may be a useful attribute during production of enzyme itself as heat may be used to destroy contaminant enzyme activity. In addition to pH and temperature, the stability of enzyme is also increased by many factors such as: (a) high concentration of respective enzymes (as protein aggregates and protects them), (b) presence of their substrate and/or product (e.g. amylase shows more stability in the presence of starch than in its absence), (c) presence of ions (e.g.  $\alpha$ -amylase is denatured within 4 h in the absence of cell), and (d) reduced amount of water content in reaction mixture (for example, at natural conditions  $\beta$ -galactosidase results in production of glucose and galactose from hydrolysis of lactose in whey. However, the same enzyme produces some glucose and galactose and mixture of trisaccharides from the same concentrated whey.

**Substrate Specificity:** Organic matter contains the various constituents such as cellulose, hemicellulose, lignin, etc. in a complex matrix. In nature these are decomposed and mineralized by a variety of microorganisms. However, it is not possible for a single microbe to decompose all the constituents. For example, a cellulose decomposer will fail to decompose the lignin because of the presence of only cellulose. Therefore, on the decomposing materials community dynamics of microorganism, i.e. changing community of microbes with time exists till the disappearance of complex organic matter.

It is also possible that a particular microbe develops potentiality to secrete an enzyme in high amount and utilize the substrate more rapidly than others. This inherent capacity makes the microbes capable to compete in the microbial competition for substrate utilization. Due to possession of this activity i.e. high enzyme producing ability, exploitation of microorganisms is done. For example, *Trichoderma reesei* secretes cellulase in high amount; therefore, this fungus is used for commercial production of cellulase.

**Activation and Inhibition:** Some enzymes obtained from different sources show difference in responses to a given activator or inhibitor. For example,  $\beta$ -galactosidase isolated from fungi does not require cobalt, whereas the same of bacterial origin requires cobalt as a cofactor. Thus cobalt activates  $\beta$ -galactosidase isolated from bacteria and inhibits it when obtained from fungi. Examples of some activators of enzymes used commercially are proteins (for proteases) starch (for  $\alpha$ -amylase), cellulose (for cellulase) and pectin (for pectinase).

**Stability:** The stability of the enzymes might be expected to either increase or decrease on insolubilization, depending on whether the carrier provides a microenvironment capable of denaturing the enzymic protein or of stabilizing it. Inactivation due to autodigestion of proteolytic enzymes should be reduced by isolating the enzyme molecules from mutual attack by immobilizing them on a matrix. It has been found that enzymes coupled to inorganic carriers were generally more stable than those attached to organic polymers when stored at 4 or 23° C. Stability to denaturing agents may also be changed upon insolubilization.

**Kinetic Properties:** Changes in activity of enzymes due to the actual process of insolubilization have not been studied very much. There is usually a decrease in specific activity of an enzyme upon

insolubilization, and this can be attributed to denaturation of the enzymic protein caused by the coupling process. Once an enzyme has been insolubilized, however, it finds itself in a microenvironment that may be drastically different from that existing in free solution. The new microenvironment may be a result of the physical and chemical character of the support matrix alone, or it may result from interactions of the matrix with substrates or products involved in the enzymatic reaction.

The Michaelis constant has been found to decrease by more than one order of magnitude when substrate of opposite charge to the carrier matrix was used. Again, this only happened at low ionic strengths, and when neutral substrates were used. The electrostatic potential was calculated by insertion of the Maxwell-Boltzmann distribution into the Michaelis-Menton equation using the changes in Michaelis constant, and good agreement was obtained with the value for the electrostatic potential calculated from the pH-activity shifts.

The diffusion of substrate from the bulk solution to the micro-environment of an immobilized enzyme can limit the rate of the enzyme reaction. The rate at which substrate passes over the insoluble particle affects the thickness of the diffusion film, which in turn determines the concentration of substrate in the vicinity of the enzyme and hence the rate of reaction.

The effect of the molecular weight of the substrate can also be large. Diffusion of large molecules will obviously be limited by steric interactions with the matrix, and this is reflected in the fact that the relative activity of bound enzymes towards high molecular weight substrates has been generally found to be lower than towards low molecular weight substrates. This, however, may be an advantage in some cases, since the immobilized enzymes may be protected from attack by large inhibitor molecules.

## 2.9. APPLICATIONS OF IMMOBILIZED ENZYMES

Immobilized enzymes have considerable practical applications in industries, medicine and model studies. In 1969, Tanabe and Seiyaku developed a satisfactory industrial application for an immobilized enzyme.

Immobilized enzymes are used as analytical agents in enzyme electrodes. The enzyme electrode is made up of a glass electrode surrounded by a thin film of immobilized enzyme. Enzyme electrodes are very sensitive. They detect the presence of certain substances even if they occur in small amounts. Now, enzyme electrodes are available to detect drugs, pesticides, toxins, glucose level in blood, etc.

1. In food industries, immobilized enzymes play the following important roles: They are used to convert starch into glucose.
2. Milk whey contains lactose. The immobilized enzymes are used to convert the whey into simple sugars.
3. Immobilized enzymes are used in the preparation of cottage cheese.
4. Immobilized glucose isomerase enzyme is used in the manufacture of fructose syrup.
5. In dairy industries, the immobilized enzymes are used to coagulate the milk protein during cheese-making and to treat the waste whey.
6. Immobilized aminocyclase enzyme is used in pharmaceutical industry. This enzyme converts D.L-acyl amino acids into L-amino acids. The L-amino acids are used as ingredients in food stuffs. The immobilized technique also used for the continuous production of L-aspartic acid from ammonium fumarate, using immobilized cells of *Escherichia coli* with an increased aspartase activity.
7. Immobilized enzymes are used in enzyme therapy. The enzyme asparaginase is covalently bound with zinc ion's. and used in the treatment of leukaemias. Zinc ions and used to treat diabetics. Zinc increases the survivability and reaction potential of the insulin.
8. Immobilized enzyme reaction is used as a model system to determine the characteristic of cellular metabolism in living cells under different physiological conditions.
9. Sugar and sugar syrup manufacture by enzyme technology has received much attention from food companies in the USA. Fructose manufactured by using glucoamylase and glucose isomerase, is being produced on a large scale to replace sucrose as a sweetening agent
10. Production of high fructose syrup with the aid of immobilized enzyme is now approaching five million tons a year. The cost of the enzymatic transformation, using immobilized glucoamylase and glucose isomerase in continuous reactors, is 0.28% of the total cost of the final product. This cost is only one-tenth of that involved in enzymatic transformation in batch processes using native enzymes.

**SHORT QUESTIONS**

1. Biocatalysts.
2. Immobilized enzymes
3. Encapsulation
4. Enzyme engineering
5. Penicillin GN acylase
6. Immobilization of cells
7. Single Cell Protein (SCP)
8. Enzyme Entrapment.
9. Encapsulation
10. Covalent bonding
11. Co-polymerization

**QUESTIONS**

1. Write notes on milk fermentation.
2. Give an account on food fermentation.
3. Explain the properties of enzymes.
4. Describe the fermented food products.
5. Discuss the uses of biotechnology in food fermentation
6. Explain applications of immobilized Enzymes.
7. Give an illustrated account of methods of enzyme immobilization.
8. Write an essay on application of enzymes.
9. Write an essay on microorganisms producing useful enzymes.
10. What are the properties of enzymes?
11. Write an essay on microorganisms producing useful enzymes.
12. What is immobilization of enzymes? What are the advantages in using them?
13. Give an illustrated account of methods and effects of enzyme immobilization.
14. Write an essay on application of enzymes.

### 3. ENERGY AND ENVIRONMENTAL BIOTECHNOLOGY

#### 3.1. Biological Fuel Generation

#### 3.2. Ethanol From Biomass

#### 3.3. Methane From Biomass

#### 3.4. Waste Water Treatment

#### 3.5. Sewage Treatment

#### 3.6. Bioremediation

#### 3.7. Oil Spill Clean Up

#### 3.8. Microbial Mining

#### 3.1. BIOLOGICAL FUEL GENERATION

The inflammable substances produced by the action of microbes, that can be set on fire are called biofuel. The biofuels are derived from biomass such as ethanol and methane. They are being produced from cheap raw materials or wastes. They do not release high proportion of carbon dioxide during combustion. This is the advantage of biofuels in monitoring air pollution due to carbon dioxide accumulation.

The production of biofuels to replace oil and natural gas is in active development, focusing on the use of cheap organic matter (usually cellulose, agricultural and sewage waste) in the efficient production of liquid and gas biofuels which yield high net energy gain. The carbon in biofuels was recently extracted from atmospheric carbon dioxide by growing plants, so burning it does not result in a net increase of carbon dioxide in the earth's atmosphere. As a result, biofuels are seen by many as a way to reduce the amount of carbon dioxide released into the atmosphere by using them to replace non-renewable sources of energy.

Forest biomass has been the main source of energy for the world. Nearly 173 billion tons of wood is produced every year by means of photosynthetic production. However, the consumption of fuel wood and fossil fuel is nearly 20 times more than the photosynthetic production. Wood, charcoal and dried cow dung accounted for 85% of the total energy consumption of the world. About 15% energy is supplied by biofuels. In 1980, India produced 6 million hectoliters of ethanol from the fermentation of molasses, of which 80,000 hectoliters were used by the chemical industry.

#### Classes of Biofuels

**Solid:** There are many forms of solid biomass that are combustible as a fuel such as:

1. Wood.
2. Straw and other dried plants such as Miscanthus.
3. Animal waste such as poultry droppings or cattle dung.
4. Crops such as maize, rice, soybean, peanut and cotton (usually just the husks or shells) including Sugarcane- or agave-derived bagasse.

Dried compressed peat is also sometimes considered a biofuel. However it does not meet the criteria of being a renewable form of energy, or of the carbon being recently absorbed from atmospheric carbon dioxide by growing plants. Though more recent than petroleum or coal, on the time scale of human industrialisation it is a fossil fuel and burning it does contribute to atmospheric CO<sub>2</sub>.

**Liquid:** There are also a number of liquid forms of biomass that can be used as a fuel:

1. Bioalcohols-see alcohol as a fuel.
2. Ethanol produced from sugar cane is being used as automotive fuel in Brazil. Ethanol produced from corn is being used as a gasoline additive (oxygenator) in the United States.
3. Methanol, which is currently produced from natural gas, can also be produced from biomass — although this is not economically viable at present. The methanol economy is an interesting alternative to the hydrogen economy.
4. Butanol is formed by A.B.E. fermentation (Acetone, Butanol Ethanol) and experimental modifications of the ABE process show potentially high net energy gains with butanol being the only liquid product.

Butanol can be burned "straight" in existing gasoline engines (without modification to the engine or car), produces more energy and is less corrosive and less water soluble than ethanol, and can be distributed via existing infrastructures.

5. Biologically produced oils (bio-oils) can be used in diesel engines.
6. Straight vegetable oil (SVO).
7. Waste vegetable oil (WVO).
8. Biodiesel obtained from transesterification of animal fats and vegetable oil, directly usable in petroleum diesel engines.
9. Oils and gases can be produced from various wastes:  
Thermal depolymerization can extract methane and oil similar to petroleum from waste.
10. Methane and oils are being extracted from landfill wells and leachate in test sites.

### **Gaseous**

1. Bio-methane produced by the natural decay of garbage or agricultural manure can be collected for use as fuel.
2. Wood gas can be extracted from wood and used in petrol engines.
3. Hydrogen can be produced in water electrolysis or, less ecologically, by cracking any hydrocarbon fuel in a reformer, some fermentation processes also produce hydrogen, such as A.B.E. fermentation.
4. Gasification, that produces carbon monoxide.

### **Ethanol as Fuel**

The largest single use of ethanol is as a motor fuel and fuel additive. The largest national fuel ethanol industries exist in Brazil and the United States. The Brazilian ethanol industry is based on sugarcane; as of 2004, Brazil produces 14 billion liters annually, enough to replace about 40% of its gasoline demand. Most new cars sold in Brazil are flexible-fuel vehicles that can run on ethanol, gasoline, or any blend of the two.

### **Biomass to Liquid (BTL)**

It is a (multi step) process to produce liquid fuels out of biomass. Ethanol is produced by using a wide variety of substrates or raw materials. The utilization of correct raw materials depends on the availability of the materials and the cost of the materials.

### **Microorganisms Useful for the Production of Ethanol**

1. *Zymomonas mobilis* has a strong tendency to produce ethanol by consuming carbohydrates ( simple sugars).
2. *Thermoanaerobacter ethanolicus* also produces enough amount of ethanol during fermentation.
3. The species of *Monilia* and *Fusarium* produce ethanol directly from carbohydrate wastes.

## **3.2. ETHANOL FROM BIOMASS**

**Properties of Ethanol:** Ethanol (Ethyl alcohol) is a colourless, inflammable liquid. It is spirituous in odour. It is also known as grain alcohol, spirit and gasohol. It is a good solvent for fats, resins, dyes, etc. It can be used as a fuel for lamps and stoves. In recent years, it is also used to run internal combustion engines.

**Role of microbes:** In biotechnology based industries, ethanol is produced from wastes by the action of microbes. Any waste rich in carbohydrate is used as the substrate to produce ethanol. Usually wastes are renewable resources being released in the environment by the activity of man. Therefore, there is no need to use living natural resources to make ethanol. As wastes are taken as raw materials, ethanol production opens a way to reuse wastes to clean up the environment.

Ethanol is prepared from the following wastes and plant products: sugarcane molasses, grain of cane juice, maize, sugar beets, com, sugar beet, molasses, sweet sorghum, cassava, yams, crop wastes, etc.

Carbohydrates are found locked in wastes. The complex polysaccharides are converted into simple sugars. It is carried out by *Closteridium thermoeellum*, *C. aermaltydosulphuricum* and *C.*

*thermosaccharolyticum*. The simple sugars are converted into ethanol by *Zymomonas mobilis*, *Thermoanaerobacter ethanolicus*, etc. Some microbes produce ethanol directly from carbohydrate wastes. Eg. *Monifia*, *Fusarium*, etc.

### Industrial Production of Ethanol

Ethanol production involves the following steps:

1. Formulation of medium.
2. Designing of fermentation system.
3. Culture of microbes in fermenters.
4. Recovery of ethanol.

#### 3.2.1. Formulation of Medium

The sugar concentration of cane molasses and of other carbohydrates in the waste is diluted to 10-18%. This sugar concentration favours the growth of the microorganisms. Ammonium sulphate or ammonium phosphate is added to the diluted medium. The pH of the medium is adjusted to 4 - 5 by using dilute sulphuric acid. The starchy media like corn, rye and barley are hydrolysed with dilute acids before they are pumped into the fermenter. The hydrolysis of starch yields simple sugars which are directly converted into ethanol. Sometimes starchy feed stock is treated with amylase enzyme, extracted from *Aspergillus* and *Rhizopus*. Amylase converts the starch into 80% maltose and 20% dextrine that can easily be converted into glucose.

#### 3.2.2. Design of Fermentation System

The fermentation system (Fig. 15) consists of three molass tanks, three seed tanks, a fermenter and a wash chamber. Among the three molass tanks, one is larger in size. It is loaded with a large volume of molasses. It is named molass storage tank. The stored molasses enter another tank where the molasses are diluted properly with water. The diluted molasses then enter the sterilization tank for sterilization. The sterilized medium is used to carry out fermentation.

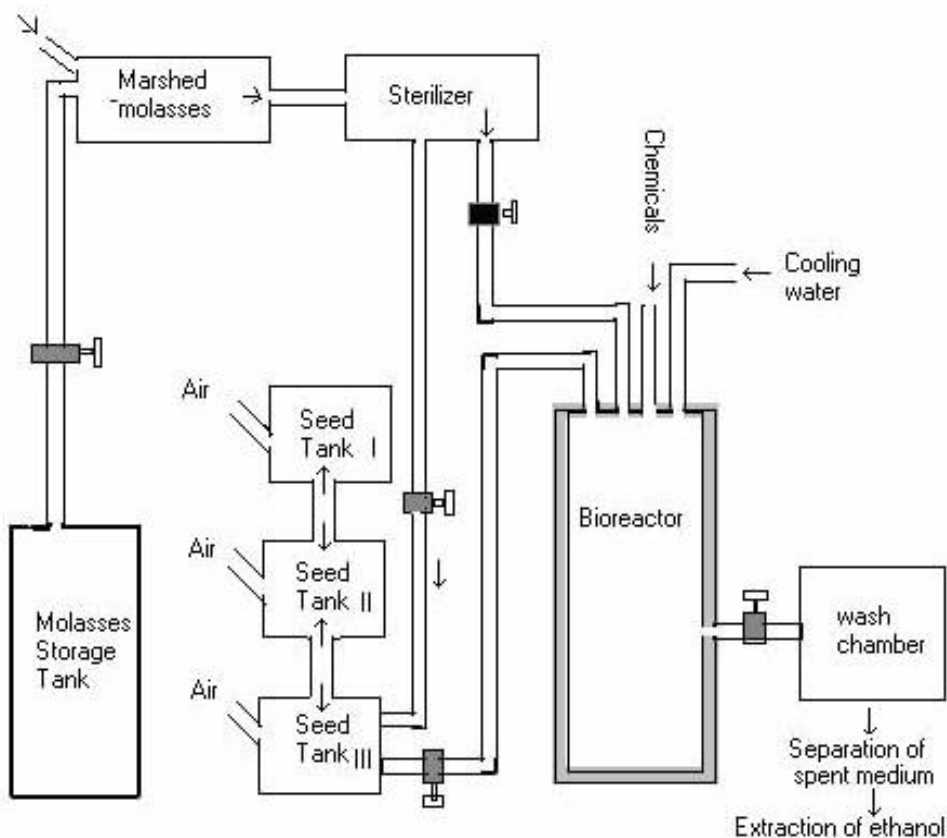

Fig. 15. Structure of an ethanol fermentation system.

The seed tanks are rather smaller vessels which are interconnected by pipelines. Microbes are cultured in the seed tanks and supplied to the fermenter to carry out ethanol fermentation.

A fermenter is a large vessel to carry out ethanol production. It has three inlets at its top to receive sterilized medium from the sterilization tank, inoculum from seed tank and chemicals. It has an outlet at the base to harvest the broth. The fermenter is cooled by a water jacket. The fermenter is connected with a wash chamber by a pipeline. Harvested broth is transferred to the wash chamber for distillation.

### 3.2.3. Culture of Microbes in Fermenter

Sterilized medium in the sterilization tank is pumped into the fermenter. Then microbial inoculum is pumped into the fermenter to carry out ethanol fermentation. Temperature inside the fermenter is regulated by circulating cold water through the water jacket. 33°C temperature is found to be suitable for fermentation. Ethanol fermentation is complete in about 3 days.

The enzyme invertase of *Zymomonas* (yeast) converts sucrose in the molasses into glucose. This glucose is converted into ethanol by the enzyme zymase.

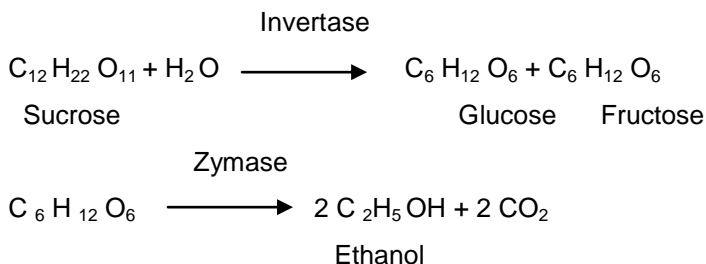

### 3.2.4. Recovery of Ethanol

The fermented broth in the fermenter is known as wash. It is distilled in the wash chamber to recover ethanol. The distillation set up is called coffee still. It consists of two tall fractionating columns provided with perforated plates. One column is called analyser and the other is called rectifier.

Wash flowing through a folded pipe is heated in the rectifier. This pipe releases the contents at the top of the analyser. Steam is passed through the base of the analyser to carry the alcohol vapour to the base of the rectifier. The spent liquor is collected from the outlet of the analyser. Alcohol vapour in the rectifier is collected through a pipe jacketed with 'cool water to get 95 % ethanol.

### Applications of Ethanol

1. Ethanol is an active solvent of dyes, lubricants, adhesives, some pesticides, paints, explosives and resins. It is also used as an organic solvent for the extraction of some organic compounds from living things.
2. Ethanol is used in the manufacture of synthetic rubber.
3. It is used in the manufacture of synthetic fibers like rayon, polyester, etc.
4. It is used in the extraction of certain pharmaceutical products.
5. It is used in the manufacture of acetaldehyde.
6. It is used in the manufacture of perfumes.
7. Ethanol is used as fuel in internal combustion engines. It is used in unhydrated form (99.8% ethanol) or mixed with petrol or in the form of hydrated ethanol. In most cases, 15% or 10-20% of ethanol is mixed with petrol for fuel purpose in engines and in chemical industries. The energy contents of ethanol are 19 MJ.
8. In Brazil nearly one-third of cars are running by consuming ethanol as fuel.
9. Americans use ethanol along with petrol for running their cars. They are marketing petrol along with ethanol.
10. India produces nearly 10 million hectolitres of ethanol per year.
11. Ethanol is a renewable source of energy that can be made from any starchy waste. It never releases smoke in the atmosphere while burning. Therefore, ethanol seems to be an ideal liquid fuel for the third world.

### 3.3. METHANE FROM BIOMASS

Methane is a fuel gas or biogas produced from biomass. It is produced by fermentation effected by anaerobic bacteria called methanogens. The microbial conversion of biomass into methane was first discovered by Volta in 1776. Volta demonstrated the presence of methane in marsh gas. Hence, the biogas is known as marsh gas. It is also named Klar-gas, refuse derived fuel (RDF) and gobar gas.

#### Production of Methane

Biogas production involves the following important steps:

1. Selection of feedstock.
2. Selection of methanogens.
3. Construction of biogas plant.
4. Methane fermentation.

#### 3.3.1. Selection of Feed Stock

The organic waste that is used in fermentation is called feedstock. Generally, cattle dung, pig dung, goats excreta are used as feed stock for the production of biogas. Sugarcane bagasse, com stubble, straw urine, poultry droppings, fishery wastes, blood, meat, refuses, oil cake, rice bran, plant residues, etc. are also used as feed stock.

#### 3.3.2. Selection of Methanogens

Microorganisms which produce methane under anaerobic conditions are called methanogens. The important methanogenic microbes are: *Methanobacterium*, *Methanobrevibacter*, *Methanococcus*, *Methanomicrobium*, *Methanospirillum* and *Methanosarcina*.

Methanogens show the following salient features:

1. Methanogenes are anaerobes.
2. They are mesophilic, i.e. grow at 21-45.1° C.
3. They have co-enzyme M that reduces methyl group into methane.
4. They contain unusual electron carriers such as co enzyme F420, Factor F430. The usual electron carriers quinones and ferridoxins are absent.
5. They contain adenine nucleotide translocase enzyme in the cell membrane.
6. The tRNA has no Ty C sequence.
7. RNA polymerase does not show the usual  $\text{PI}, \text{Pa } 2, 7$  structures.
8. The cell wall has heteropolysaccharide instead of murine.
9. Usually mixed culture of more than one methanogenic bacteria is used to produce biogas. Biogas slurry has many methanogenic species. A small volume of the slurry is directly used as inoculum to carry out biogas production.

#### 3.3.3. Construction of Biogas Plant

Two types of biogas plants are constructed to produce biogas. They are floating gas holder type and fixed dome type. The structure of these biogas plants is explained below:

**Floating Gas Holder Type Biogas Plant:** A typical floating gas holder type biogas unit (Fig. 16) mainly consists of two parts: one is a fermenter to effect gas production; and the other is a gas-holder to collect the gas produced in the fermenter.

The fermenter has an inlet to add slurry and semi-solid wastes into the fermenter and an outlet to remove the digested slurry. The complete biogas production is effected in it.

The gas-holder is a large-sized drum kept above the fermenter to collect the gas produced in the fermenter. The gas-holder has an outlet to supply the gas for distribution. The gas-holder collects the gas released from the fermenter and moves upwards. When the gas is used, simultaneously the gas-holder moves downwards.

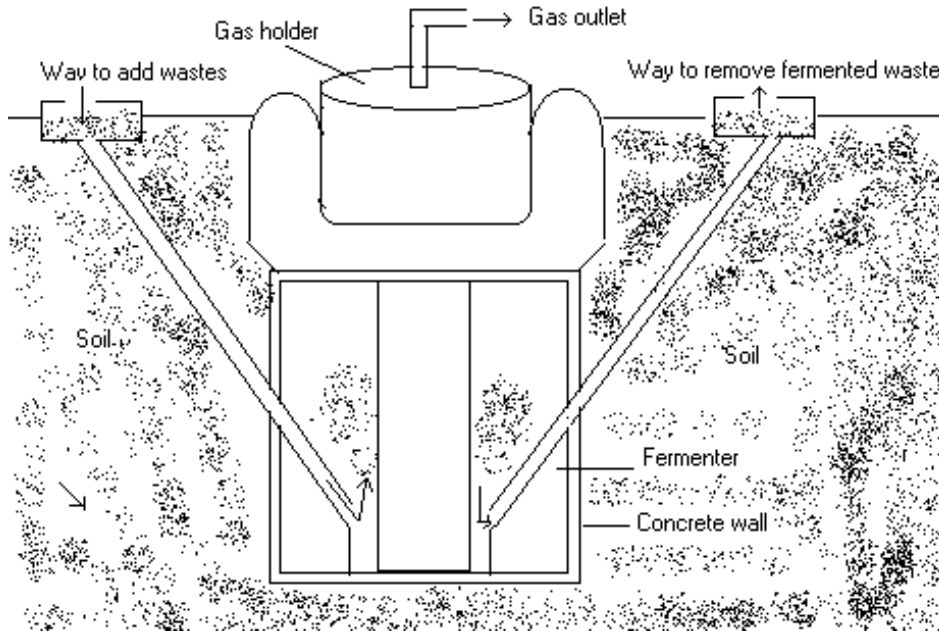

Fig. 16. Structure of Indian biogas plant.

**Fixed Dome Type Biogas Plant:** Here the gasholder and the fermenter are designed as a combined unit. It is kept in the soil. The gas-holder is a dome-like structure firmly fixed with the fermenter (Fig. 17).

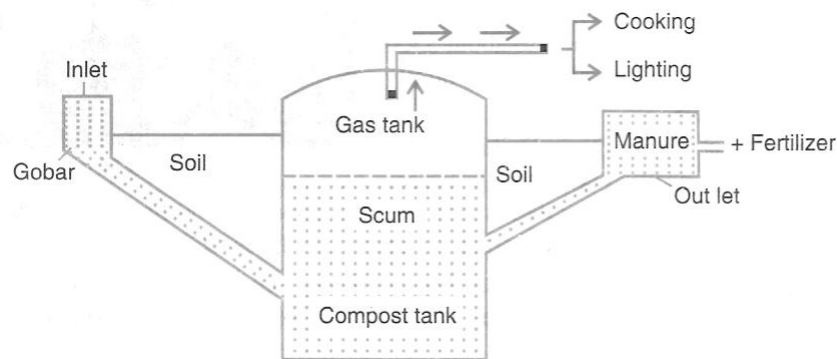

Fig. 17. Diagram of Fixed Dome Type Biogas (Gobar gas) Plant.

Gas is produced in the fermenter. This gas rises up and collected in the gas-holder. When the pressure of gas inside the gas-holder reaches the maximum, the gas pushes the digested slurry downwards. So digested slurry comes out through the outlet. Then fresh slurry is added into the fermenter through the inlet.

The Indian biogas plant is designed to get good quality gas, but the Chinese system is designed to get food quality manure and some amount of gas.

On the basis of the shape of the biogas units, the biogas plants are named spherical digester, global digester, rectangular digester and bottle-shaped digester. The digester may be built with gravels, bricks, or concrete.

### 3.3.4. Methane Fermentation

Cow dung is diluted to 50% by adding water to it. As a result, the solid and liquid ratio becomes 1: 1. That is, 50 kg of animal excreta or household refuse is diluted by adding 50 kg of water. This concentration favours the growth of acetogenic and methanogenic bacteria. The diluted feedstock is then pumped into the fermenter (biogas plant).

A small amount of digested slum is taken from a working biogas plant and used as inoculum. The inoculum is pumped into the fermenter. If slurry is not available, cultures of acetogenic and methanogenic bacteria are inoculated into the fermenter.

In industries, the culture conditions are modified suitably in the following ways to produce more biogas:

Cellulytic microorganisms inoculated are inoculated into the fermenter.

1. The bacteria capable of de are added into the fermenter. Eg. *Bacteroides ruminocia*.
2. Sulphur bacteria in the feed stock are destroyed by heat shock.
3. The pH of the medium is increased by adding lime.
4. 25-45°C temperature is maintained in the fermenter.
5. Generally, the C/N ratio 30: 1 is preferred for the best growth of methanogenic bacteria. So, the CN ratio is modified to 30: 1 by adding specific wastes to the feed stock.
6. The feed stock is stirred well.
7. Pathogenic bacteria are killed by heat shock treatment at regular intervals of 45 days.
8. Poultry- waste produces biogas within 20 days after inoculation. It produces nearly 380 cm<sup>3</sup>/Kg of total solid wastes. *Methanobacterium kadomensis* strain 23 is one of the important methane producers; it produces an equal amount of methane within eight days.

### Stages of Methanogenesis

Cellulose and other polysaccharides are digested by cellulolytic bacteria. Hence simple sugars are formed, Eg. *Closteridium thermocellum*, *Methanobacterium ruminarium*, *Bacterioides ruminicola*, etc. The proteolytic bacteria degrade proteins into amino acids; such microbes are called hydrolytic fermentative bacteria.

A second group of bacteria converts the sugars, amino acids, methanol, glycerol, and fatty acids into acetate, formate and propionate. These bacteria are called proton-reducing acetogenic bacteria.

Yet another group of acetogenic bacteria converts the formate into acetate. They are named homoacetogens. The acetate is converted into methane and carbondioxide. This reaction is carried out by a group of bacteria called acefoclastic methanogetis or acetate respiring bacteria. Eg: *Methaitosarcina barkeri*.

Some microorganisms convert the formate into carbon dioxide and hydrogen and finally the CO<sub>2</sub> and H<sub>2</sub> are converted into methane and water. These microbes are called hydrogen oxidizing methanogens (HOM). eg. *Methatiobacterium*, *Methanogenium* and *brevibacter*, *feltaiicoectis*, *Methanomicrobium*, *Methanogeinum* and *Methanospirillum*.

### Biochemistry of Methane Formation

A number of membrane-bound electron carriers and soluble components take part in the formation OH methane. However, the exact roles of these components are still uncertain. Eg. cytochrome B., FAD, Cytochrome-M, etc.

Hydrogenase is found in the membrane of methanogens. This enzyme oxidizes hydrogen into two protons. The protons are used to reduce CO<sub>2</sub> into CH<sub>2</sub>.

J.A. Romesser (1978) worked out a simple path way of methane formation. According to him an electron carrier 'X' transfers electrons to CO<sub>2</sub> and forms X-COOH.

This X-COOH readily accepts a proton (H<sup>+</sup>) and becomes H<sub>2</sub>O and X-CHO. The X-CHO donates the CHO group to coenzyme M. During this reaction, the electron carrier is set free to take another CO<sub>2</sub> molecule.

This coenzyme CHO complex accepts a hydrogen molecule and becomes a reduced coenzyme-M complex. The reduced coenzyme-M complex receives a molecule of hydrogen and converts it into a molecule of NN ater. As a result a rnythyl coenzyme M is formed. The methyl coenzyme M accepts another proton to convert the CH<sub>3</sub> group into CH<sub>4</sub>. The coenzyme-M is released free to accept another CHO molecule from the electron carrier.

### Methane Production from Hydrocarbons

Aromatic hydrocarbons are also used as substrates for the production of methane. Benzonate undergoes metabolic breakdown into acetate formate and water. Acetate is metabolised into CO<sub>4</sub> and H<sub>2</sub>O. The formate is metabolised into CO<sub>2</sub> and H<sub>2</sub>. These CO<sub>2</sub> and H<sub>2</sub> are finally converted into methane and water. The overall reaction of methane formation is stated below:

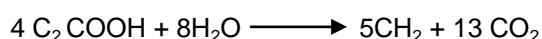

### Uses of Methane (Biogas)

The biogas produced in the gas plants is stored in gas cylinders for ready use. Kleinhanss (1983) pointed out the following uses of biogas:

1. The gas is supplied to industries in order to reduce the requirement of electricity to run machines.
2. The gas is distributed to houses as a fuel gas. It reduces the consumption of fuel wood. It is also used in emergency lights.
3. The gas is also used to produce electricity.
4. The Cholan Transport Corporation in Tamil Nadu took the first step in February 1992 to run a bus on biogas. The bus ran well during the test run. Thus, the corporation demonstrated how the problem of the shortage of petroleum could be solved by running buses and other vehicle on biogas.

The digested slurry released from the fermenter is good organic manure for the agricultural and plantation crops. Sometimes the digested slurry is used in fish cultures.

As biogas plants use wastes, biogas production technology helps to dispose organic wastes from the environment.

### 3.4. WASTE WATER TREATMENT

Biodegradation processes lead to the formation of  $\text{CO}_2$  and/or  $\text{CH}_2$  from wastewater which contain biologically degradable organic substances. The conditions under which the wastewater is discharged, stored or treated play an important part in determining how much gas is produced and its composition. Biodegradation occurs either aerobically or anaerobically. The conventional treatment of waste or wastewater is frequently aerobic. This leads to the formation of large amounts of  $\text{CO}_2$  and bacterial biomass. The process requires large amount of energy for the introduction of sufficient oxygen.

Anaerobic degradation produces much  $\text{CH}_2$ . The production of  $\text{CO}_2$  and bacterial biomass is less than with aerobic degradation. In principle, then, energy can be extracted from the process in the form of methane gas. The other products produced during anaerobic degradation (sludge and effluent) can be used in food production. The effluent for instance, may be used for irrigation. The nutrients and raw materials present in the effluent can also be recovered (Fig. 18).

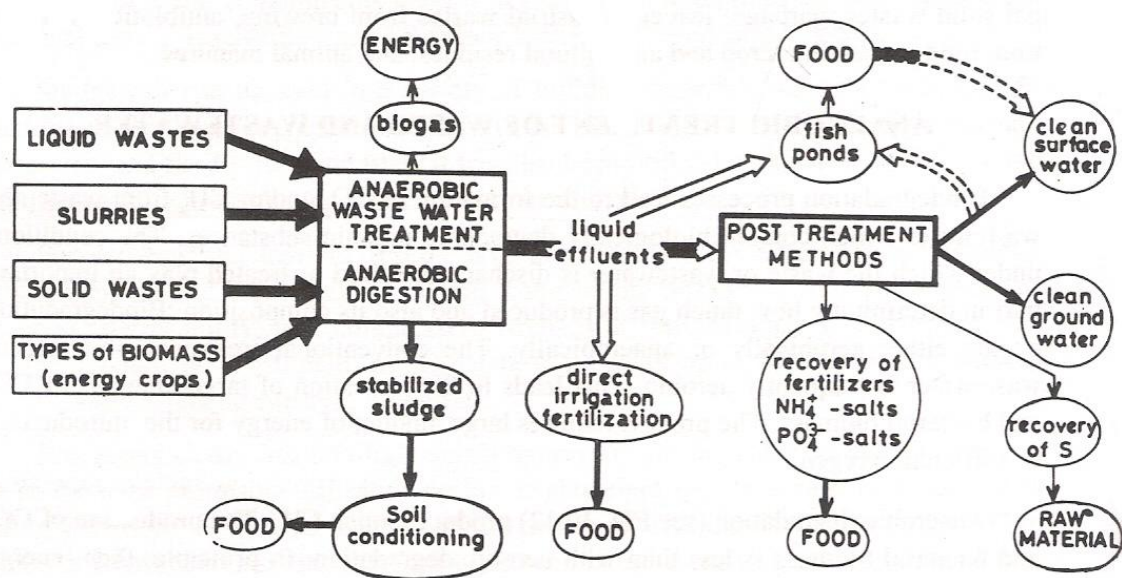

Fig. 18. Anaerobic purification technologically focused on treatment and recovery.

Biological treatment of waste waters is not new: only new dimensions are being added to the process. Attempts are now underway to develop compact wastewater treatment plants (i.e. those for on-site use such as an industrial site or for local treatment such as at the end of the road rather than at the end of a large and expensive pipeline which latter is the norm throughout the world). The compact plant will contain anaerobic and aerobic sections to utilize biological actions to consume most of the waste, while a membrane separation system will be used to remove the remaining unacceptable waste.

Site contamination is believed to be the time bomb of waste disposal because no one is clear about the dimensions of the problem. There is need for a project which will utilise sophisticated geophysical techniques to locate below ground contaminations such as hydrocarbons.

**Immobilisation Techniques in Waste Water Treatment:** The immobilisation of cells and enzymes are used in waste water treatment to reduce BOD, detoxify pollutants and bio conversion of waste to get specific product. Flocculation of cells that occurs in activated Sludge process may be considered as crude or preliminary way of using immobilised enzyme.

Use of immobilisation enzyme is suggested for treatment, wastewater from the wheat and starch industry. In one approach *Micrococcus denitrificans* cells can be encapsulated for reduction of nitrate to nitrite. *Nitrosomonas* cells immobilised in alginate have been used to oxidise ammonia in waste water to  $\text{NO}_2$  and  $\text{NO}_3$  which prevents algae growth.

### 3.5. SEWAGE TREATMENT

Sewage contains industrial effluents, organic materials like human waste, food waste and cleansing compounds. Sewage contains both pathogenic and non pathogenic microorganisms.

The main components of sewage are 99.5 % of water and 0.1-1 % inorganic and organic matter in Suspended soluble form. It also has higher BOD value. The Biological Oxygen Demand (BOD) designates the amount of degradable organic material present in the water sample. Decrease in BOD of waste water during treatment reflects the effectiveness of treatment in transforming organic to inorganic waste. In addition, sewage contains Suspended mineral matter, bacteria, viruses and dissolved salts. Sewage treatment is classified into three types. They are primary, secondary and tertiary treatment.

#### 1. Primary treatment

Primary treatment consist of removal of large objects such as paper, rags, plastic and pieces of wood by passing the waste water through a series of screens. These are then allowed to settle for a period of at least 90 minutes to 2 hr. At this stage chemical is added to settle down flocculate particles so that they undergo sedimentation rapidly.

#### 2. Secondary Treatment

Secondary treatment of sewage is designed to stabilize organic materials and reduce BOD in the sewage. In secondary treatment, microorganisms like bacteria and fungi are used to biodegrade organic materials present in the supernatant of the sedimentation tank. The conventional activated sludge process involves nutrient (phosphorus) removal from the wastewater, aeration using micro-organisms to consume organic matter, and clarification to settle microorganisms.

**Nutrient (Phosphorus) Removal:** The conventional activated sludge process involves nutrient (phosphorus) removal from the wastewater, aeration using micro-organisms to consume organic matter, and clarification to settle microorganisms.

**Nutrient (Phosphorus) Removal:** As the wastewater enters the aeration tank, ferrous chloride is added to remove phosphorous. The ferrous chloride makes the phosphorous in the wastewater settle to the bottom in the final clarifiers.

**Aeration Tanks:** Large, dense populations of bacteria, protozoa, and other microorganisms consume suspended and dissolved organic matter in the aeration tanks. As the micro-organisms need oxygen to live, air is pumped through diffusers in the base of the tanks. The rising bubbles of air also provide a mixing action, keeping the micro-organisms suspended and in contact with the wastewater (Fig. 19).

#### 3. Tertiary Treatment

Following activated Sludge treatment, lime is added to treat water for coagulating and precipitating phosphate containing particles. These are then settled in clarifier. Some of the filters, made of coal and sand remove remaining particulars. Activated charcoal removes detergent, pesticides and other toxic materials. Chlorine is added to purify water in the final step to destroy remaining microorganisms. Further, chemical precipitation removes phosphates and nitrates.

### 3.6. Bioremediation

Bioremediation can be defined as any process that uses microorganisms or their enzymes to return the environment altered by contaminants to its original condition.

Bioremediation is the cleaning up of toxic contaminants in the environment using the activity of natural microbial populations in the contaminants or other wastes. It is mainly concerned with the treatment

of hazardous substances such as oil sludges in the soil, chlorinated pesticides and radioactive wastes in effluents. Here microbes act as catalysts to reduce the level of hazardness of toxic chemicals. So, living beings have not been affected by the chemicals.

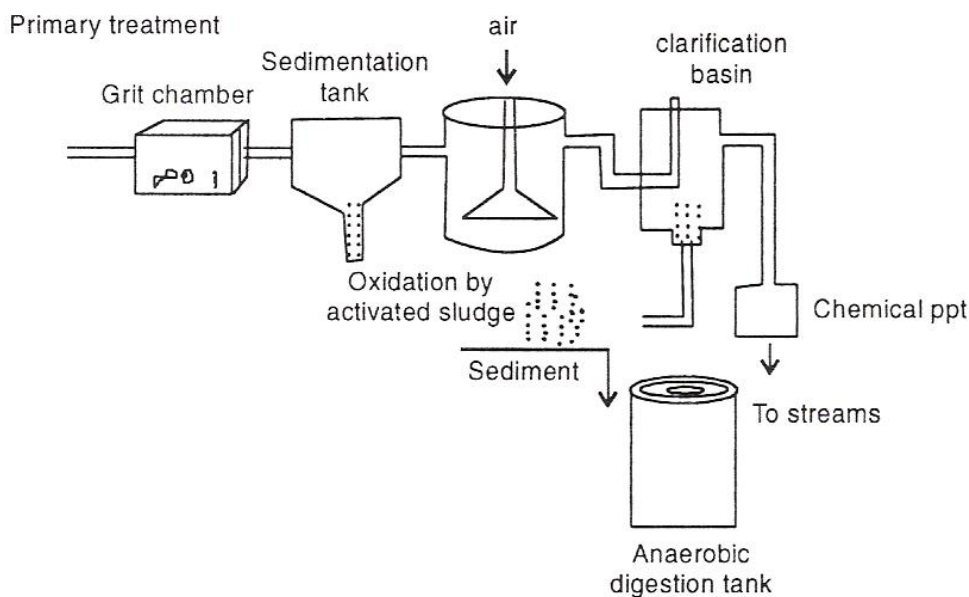

Fig. 19. Sewage treatment plant.

Enormous quantities of organic and inorganic compounds are released into the environment each year as a result of human activities. In some cases these releases are deliberate and well regulated (e.g. industrial emissions) while in other cases they are accidental (e.g. chemical or oil spills). Petroleum and its products are one of the most common environmental pollutants. They are a fire hazard, threat to marine life, and a source of air and groundwater pollution. They contaminate land and water bodies by accidental spills like the Alaska Oil spill in 1989 and oil spills during the Gulf War, leakage from pipelines, and other human activities. Detoxification of the contaminated sites is expensive and time consuming by conventional chemical or physical methods.

Bioremediation consists of using naturally occurring or laboratory cultivated microorganisms to reduce or eliminate toxic pollutants. Petroleum products are a rich source of energy and some organisms are able to take advantage of this and use hydrocarbons as a source of food and energy. This results in the breakdown of these complex compounds into simpler forms such as carbon dioxide and water. Bioremediation thus involves detoxifying hazardous substances instead of merely transferring them from one medium to another. This process is less disruptive and can be carried out at the site which reduces the need of transporting these toxic materials to separate treatment sites.

The technique has many applications as it is highly cost-effective. As the technique can usually be applied in situ, the cost of removing or transporting the waste material for off-site treatment is eliminated. In some cases, however, bioremediation is accomplished by bringing portable bioreactors to the waste site.

### 3.6. BIOREMEDIATION PROCESSES

Bioremediation processes are being developed to degrade plastics and petrochemical contaminants of soil and water. These substances are often quite refractory to degradation by single microbial strains with the pollutant. The pollutants are the sole source of carbon but are degraded by co-metabolism with appropriate second substrates and by mixtures of microbial species. Environmental pollution may also be attacked at the prevention level. Chemical fertilizers which lead to eutrophication of lakes can be replaced by biofertilizers such as *Azolla* fern, which symbiotically fixes nitrogen. Efforts are underway to genetically engineer plants such as wheat and maize to accommodate symbiotic nitrogen-fixing bacteria or plasmids which confer nitrogen-fixing capabilities upon the plant.

At present hundreds of firms, provide bioremediation services in advanced countries using some 1000 strains of bacteria and fungi. The greatest success has been achieved for cleaning of sites contaminated with pentachlorophenol, used for preserving wood. Bioremediation techniques have also been designed for treating pollutants such as polychlorinated biphenyls, gasoline, and vinyl chloride.

Bioremediation is done in the following ways:

1. In situ bioremediation
2. Composting
3. Land farming
4. Digestion in above ground reactors.

### 1. In Situ Bioremediation

The removal of oil contaminants naturally from the soil or water by adding enough nutrients to the soil is called in situ bioremediation. Addition of inorganic fertilizers to such soils seeds up the rate of oil degradation by the naturally existing microbes. In situ bioremediation is very cheap to workout. It is suitable for treating large areas containing low level of oil contaminants.

### 2. Composting

Compost is a mixture of decayed organic matter, and is rich in microorganisms. These microorganisms can degrade explosive wastes that cannot be treated easily. The process of degrading explosive wastes by adding them to a pile of 646 decaying organic matter is known as composting. Explosives such as trinitrotoluene (TNT), hexahydro-trinitro-triazine (RDX), octahydro-tetranitro-tetrazocine (HMX) and tetryl in liquids are treated by composting. The liquid containing explosive wastes is added to a decaying pile of organic matter in a large compost pit. Microbes in the decaying organic matter degrade the explosive chemicals and reduce their concentration in the compost. About 90% of explosive wastes are degraded within 80 days in compost piles at 55°C. It is further lowered to less than 1% within 150 days. At that time composting is also over. The compost pile is excavated from the pit and used to fertilize the soil as usual (shown in the Fig. 20). This method is cheaper than incineration of explosive wastes.

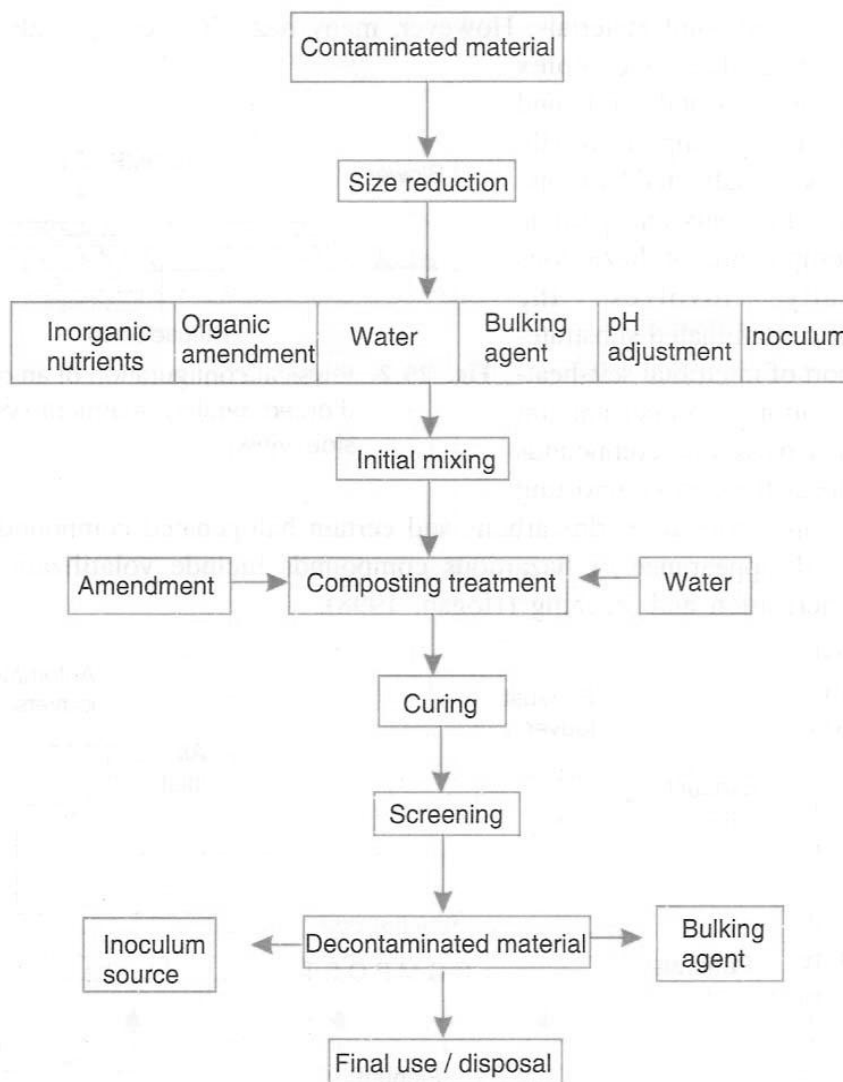

Fig. 20. Outline of composting treatment sequence.

Gradual colonization of organic materials is done by indigenous micro flora, but hazardous chemicals may inhibit microbial growth. Therefore, bioaugmentation (i.e. use of commercial or GEMs) of wastes is also recommended.

### 3. Land Farming

The piling and maintenance of oil sludge on a flat land to degrade oil wastes by microbes existing in the sludge, is known as land farming. It is done on a stretch of flat land with clay soil in order to prevent seepage of contaminated water.

Light loamy soil is spread uniformly to a height of half a foot. Oil sludge is piled over the loamy soil to a height of one foot. It is graded to have a gentle slope to prevent water logging and a ridge along the periphery of the sludge pile to prevent surface run-off.

Nitrates, phosphates and powdered lime stones are uniformly spread over the sludge. The sludge is watered to have 20% water saturation in the pile. The microbial growth is maximum when the pH is between 7 and 8 and temperature is between 20°C and 30°C. The microbes degrade 50-70% of oil wastes in the sludge within 4 months.

Again, another layer of sludge may be piled over the first pile for degradation. After full degradation of oil wastes, the sludge material is excavated and put onto its original place from which it was excavated.

Land farming has the following drawbacks:

1. Microbial degradation of oil sludge is very slow and incomplete.
2. Concentration of heavy metals increases simultaneously in land farming soils.
3. After land farming, the lands are useless for cultivation.

### Digestion in Ground Reactors

Above the ground, reactors are large concrete tanks being used for treating liquid and soil wastes. They act as fermenters. This method is found to be suitable to treat oil sludges and sewage.

1. Contaminated soil is excavated from an area and put into the reactor. The soil is treated with enough water and stirred well to form slurry.
2. Many plastic spheres: Granulated charcoal, diatomaceous earth, etc. are mixed with the slurry. They increase the area for microbial growth.
3. Anaerobic conditions are maintained inside the reactor for a considerable time. Anaerobic microbes grow well and degrade the waste.
4. As soon as the anaerobic degradation is over, the sludge is transferred to another reactor and treated with a fresh microbial inoculum. Aerobic conditions are maintained in the reactor. Due to the activity of aerobic microbes, the wastes are mineralized completely.

### Slurry-phase Treatment

The contaminated solid materials (soil degraded sediments, etc). microorganisms and water formulated into slurry are brought within a bioreactor i.e. fermenter. Thus slurry-phase treatment is a triphasic system involving three major components: water, suspended particulate matter and air. Here water serves as suspending medium where nutrients, trace elements, pH adjustment chemicals and desorbed contaminants are dissolved. Suspended particulate matter includes a biologically inert substratum consisting of contaminants (soil particles) and biomass attached to soil matrix or free in suspending medium. Air provides oxygen for bacterial growth, Slurry-phase reactors are new design in bioremediation. The objectives of bioreactor designing are to (i) alleviate microbial growth limiting factors in soil environment such as substrate, nutrients and oxygen availability. (ii) remote suitable environmental conditions for bacterial growth such as moisture, pH, temperature. and (iii) minimise mass transfer limitations and facilitate desorption of organic material from the soil matrix (Christodoulτος and Kotsospyros, 1998).

Biologically, there are three types of slurry-phase bioreactors: aerated lagoons, low-shear airlift reactor and fluidized-bed soil reactor. The first two types are in use of full scale bioremediation, while the third one is in developmental stage.

### Microbial Enhancement of Recovery (MEOR)

The process of getting more oil from oil wells by injecting suitable microbes or microbial products into the oil reservoir is called microbial enhancement of oil recovery (MEOR). It is also called tertiary oil recovery.

## 1. Recovery of Oil by Injecting Microbes

In oil reservoirs, most of the oil occurs as a coating on rock and soil particles. So it never comes out of the reservoir to the well head unless the oil is dislodged from the particles. The secondary oil recovery methods are found to be suitable to release the oil coatings.

Some anaerobic microbes along with required nutrients are pumped into the reservoir to dislodge oil present in rock particles. This method is cost effective and gives fruitful results.

**Microbes Suitable For Mechanism of Enhanced Oil Recovery (MEOR):** Aerobic bacteria, yeasts and fungi are not suitable for MEOR, as most of them fall to grow in mines. Anaerobic bacteria are the right choice for oil recovery, for many reasons. The microbes should have the following features:

1. The microbes should be smaller in size.
2. They should have the ability to survive in oil reservoirs at least for 3 months.
3. They should have the ability to withstand the temperature between 30° C and 100° C.
4. They should have the capacity to resist 50-500 atm pressure in the oil wells.
5. They should have salt resistance.
6. They should live without oxygen.
7. They could grow on cheap carbon sources.

Mixed cultures of microbes are found to be more suitable than pure cultures for enhanced oil recovery. In Poland, mixed culture of Arthobacter, Clostridium, Mycobacterium and Pseudomonas is used for enhancing the oil recovery. It increases 20-36% of the oil yield. In Romania mixed culture of Arthobacter, Bacillus, Pseudomonas, Escherichia, Micrococcus, Peptostreptococcus and Pseudomonas is used in mines. A.M. Chakrabarty (USA) has developed a strain of Pseudomonas called 'super bug' by inserting certain genes of four different Pseudomonas species. It increases the oil production upto 16-200%. In the USA, Toure culture of Clostridium acetobutylicum is pumped into the oil reservoir to enhance the oil recovery. It increases the oil production upto 200 %.

**Mechanism of Enhanced Oil Recovery:** The microbes produce hydrogen, methane, carbon dioxide, organic acids, surface active products and polysaccharides. The gases maintain the gas pressure inside the reservoir and reduce the viscosity of the oil. So the oil found on rock particles tends to move.

The organic acids like acetic acid and propionic acid increase the porosity of the rock and production of carbon dioxide. The surface active products reduce the interfacial tension between oil and water while pumping water into the reservoir. The polysaccharides increase the viscosity of flooding water to allow it to go through all channels under the applied pressure. They force the released oil towards the well head. As a result, more oil gets collected in the well head.

## 2. Recovery of Oil by Injecting Microbial Products

Oil recovery can also be enhanced by injecting certain products of microbial metabolism into the oil reserves. The products include surfactant polymers and non-surfactant polymers. They may be alcohols, acids or ketones.

## 3.7. OIL SPILL CLEAN UP

Freshwater and marine shoreline areas are important public and ecological resources. However, their cleanliness and beauty, and the survival of the species that inhabit them, can be threatened by accidents that occur when oil is produced, stored, and transported. Oil is sometimes spilled from vessels directly into waterways; spills from land-based facilities can flow into waters and foul shorelines. These accidents affect both oceans and freshwater environments.

Frequently, oil spills will start on land and reach shore areas. Whenever possible, control and cleanup of an oil spill begins immediately. If the oil spill can be controlled, it is less likely that it will reach sensitive freshwater or marine habitats. If the oil does reach the shore, however, decisions about how best to remove it must be made. These decisions will be based on factors such as the following:

1. Type of oil spilled.
2. Geology of the shoreline and rate of water flow.
3. Type and sensitivity of biological communities likely to be affected.

## Cleanup Processes and Methods

Both natural processes and physical methods aid in the removal and containment of oil from shorelines. Sometimes physical methods are used to enhance naturally occurring processes. Examples of a technology that uses both natural processes and physical methods to clean up an oil spill are biodegradation and bioremediation, which are described later.

### Biological Method

This chapter describes some of the chemical and biological methods that are used by response personnel to contain and clean up oil spills in aquatic environments. Alternative treatment typically involves adding chemical or biological agents to spilled oil and also includes in-situ burning.

### Biological Agents

Biological agents are nutrients, enzymes, or microorganisms that increase the rate at which natural biodegradation occurs.

Biodegradation is a process by which microorganisms such as bacteria, fungi, and yeasts break down complex compounds into simpler products to obtain energy and nutrients.

Biodegradation of oil is a natural process that slowly over the course of weeks, months, or years removes oil from the environment. However, rapid removal of spilled oil from shorelines and wetlands may be necessary in order to minimize potential environmental damage to these sensitive habitats.

Bioremediation technologies can help biodegradation processes work faster. Bioremediation refers to the act of adding materials to the environment, such as fertilizers or microorganisms, that will increase the rate at which natural biodegradation occurs. Furthermore, bioremediation is often used after all mechanical oil recovery methods have been used. Two bioremediation approaches have been used in the United States for oil spill cleanups: biostimulation and bioaugmentation.

### Type of Oil Spilled

Lighter oils tend to evaporate and degrade (break down) very quickly; therefore, they do not tend to be deposited in large quantities on banks and shorelines. Heavier oils, however, tend to form a thick oil-and-water mixture called mousse, which clings to rocks and sand. Heavier oils exposed to sunlight and wave action also tend to form dense, sticky substances known as tar balls and asphalt that are very difficult to remove from rocks and sediments. Therefore, deposits from heavy oils generally require more aggressive cleanup than those from lighter ones. Shoreline clean-up of inland spills usually involves lighter oils.

Therefore, deposits from heavy oils generally require more aggressive cleanup than those from lighter ones. Shoreline clean-up of inland spills usually involves lighter oils. Inland oil spills often involve refined petroleum products, although spills of other types of oil are not uncommon. Spills in marine ecosystems often involve crude oils and heavy fuel oils originating from accidents during tanker operation.

### Geology of the Shoreline and Rate of Water Flow

Shorelines can vary dramatically in their forms and compositions. Some marine shorelines are narrow, with beaches formed from rounded or flattened cobbles and pebbles; some are wide and covered in a layer of sand or broken shell fragments; and still others are steep cliffs with no beach at all.

Generally, freshwater shorelines are composed of sediments and may be lined with trees or heavy vegetation. The composition and structure of the bank will determine the potential effects of oil on the shoreline.

The effects of an oil spill on marine and freshwater habitats vary according to the rate of water flow and the habitat's specific characteristics. Standing or slow-moving water, such as marshes or lakes, are likely to incur more severe impacts than flowing water, such as rivers and streams, because spilled oil tends to "pool" in the water and can remain there for long periods of time. In calm water conditions, affected habitats may take years to recover. When oil spills into a flowing river, the impact may be less severe than in standing water because the river current acts as a natural cleaning mechanism. Currents tend to be the strongest along the outside edge of a bend in a river where the current tends to flow straight into the outside bank before being deflected downstream. Oil contamination is usually heavy in this area because currents drive the oil onto the bank.

In marine environments and on large lakes and rivers, waves affect the movement and spreading of oil spills in several different ways. Initially, the oil spreads to form a thin film, called an oil slick. The slick appears smooth compared to the water around it. Momentum is then transferred from the waves to the oil slick. Small waves tend to push oil slicks in the direction of wave propagation. This makes oil slicks move slightly faster than the surface of the water that they are floating on. Short, relatively steep waves can result

in a surface current that will move the oil in a downwind direction. As waves break, the resulting plunging water creates a turbulent wake, carrying particles of oil down into the water column.

Animals and plants may be affected by the physical properties of spilled oil, which prevent respiration, photosynthesis, or feeding.

Animals, such as elephant seals, which depend on the marine environment for breeding and pupping, can lose their ability to stay warm in cold water when their skin comes into contact with oil.

Birds lose their ability to fly and to stay warm when their feathers are coated with oil, and fish can suffocate when their gills are covered with oil. An oil spill can disrupt an ecosystem's food chain because it is toxic to some plants which other organisms may depend on for food. In addition, oil in sediments like those that are common in freshwater shorelines may be very harmful because sediment traps the oil and affects the organisms that live in, or feed off, the sediments.

Biostimulation is the method of adding nutrients such as phosphorus and nitrogen to a contaminated environment to stimulate the growth of the microorganisms that break down oil. Limited supplies of these necessary nutrients usually control the growth of native microorganism populations. When nutrients are added, the native microorganism population can grow rapidly, potentially increasing the rate of biodegradation.

Bioaugmentation is the addition of microorganisms to the existing native oil-degrading population. Sometimes species of bacteria that do not naturally exist in an area will be added to the native population. As with nutrient addition, the purpose of seeding is to increase the population of microorganisms that can biodegrade the spilled oil. This process is seldom needed, however, because hydrocarbon-degrading bacterial exist almost everywhere and non-indigenous species are often unable to compete successfully with native microorganisms.

During the Exxon Valdez oil spill cleanup and restoration activities, the Alaska Regional Response Team authorized the use of bioremediation products, including biostimulation and bioaugmentation. Nutrient addition use was approved for approximately 100 miles of the Prince William Sound shoreline. Data collected through a monitoring protocol required by the State of Alaska indicated that nutrient addition accelerated the natural degradation of oil with no observed eutrophication or toxicity. Proof of the effectiveness of bioremediation as an oil spill cleanup technology was developed on the shoreline of Delaware Bay in 1994. This EPA-funded study, which involved an intentional release of light crude oil onto small plots, demonstrated a several-fold increase in biodegradation rate due to the addition of fertilizer compared to the unfertilized control plots. Bioaugmentation or seeding with native microorganisms did not result in faster biodegradation

### **3.8. MICROBIAL MINING**

#### **(Microbial Leaching or Bioleaching or Biomining)**

The recovery of metals from tailings and ores using in microorganisms is called biomining or microbial mining. In biomining, metals in the ores are solubilized by microbes in biochemical ways. The solubilized (leached) metals in liquids are separated by sedimentation.

Ores are minerals from which metals are extracted. These ores may occur in the forms of oxides, sulphides, sulphates, carbonates and silicates. Metals have been extracted from these ores.

Microbial leaching is the process by which metals are dissolved from ore bearing rocks using microorganisms. For the last 10 centuries, microorganisms have assisted in the recovery of copper dissolved in drainage from water. Thus biomining has emerge as an important branch of biotechnology in recent years. Microbial technology renders helps in case of recovery of ores, which cannot be economically processed with chemical methods, because they contain low grade metals. Therefore, large quantity of IMN grade ores are produced during the separation of big grade ores. The low grade ores are discarded in waste heaps which enter in the environment. The low grade ores contain significant amount of nickel, lead and zinc ores which could be processed by microbial leaching. Bioleaching of uranium and copper has been widely commercialized. However, large scale leaching process may cause environmental problems when dump is not managed properly. These results in seepage of leach fluids containing large quantity of metals and low pH into near by natural water supplies and ground water.

Thus, biomining is economically sound hydrometallurgical process with lesser environmental problem than conventional commercial application. However, it is an inter-disciplinary field involving metallurgy, chemical engineering, microbiology and molecular biology. It has tremendous, practical application. In a country like India, biomining has great national significance where there is vast unexploited mineral potential.

## Microorganisms used for Leaching

The bacteria involved in the leaching of metal ores are the most remarkable phenomena among life forms. The central role of bacteria in the leaching of copper from inferior ore went unrecognized. The rock-eating microorganisms are said to be chemolithotrophic. They obtain energy from the oxidation of inorganic substances.

To bacteria are being deliberately exploited to recover millions of tonnes of copper from billions of tonnes of inferior ores. More than ten percent copper ore recovered in US is from bioleaching process. The use of bioleaching process overcomes pollution level caused during biological method of burning of sulphuric fossil fuel and sulphide minerals. For many years it was thought that the only which helps in leaching of metal from ore was the rod-shaped bacteria. This bacteria was discovered in 1957 in acid water. In recent years other microorganisms have been discovered. Among these iron-oxidizing organisms, bacteria are the most popular, widely studied and are currently the major leaching organisms. Leaching is generally done by bacterial action directly on the ore to extract metal or the bacteria produces substances such as ferric iron and sulphuric acid which then extract metal.

The most commonly used microorganisms for bioleaching are *Thiobacillus thiooxidans* and *T. ferrooxidans*. The other microorganisms may also be used in bioleaching viz., *Bacillus licheniformis litteus*, *B. Megaterium*, *B. polymyxa*, *Leptospirillum ferrooxidans*, *Pseudomonas fluorescens*, *Sulfolobus acidocaldarius*, *Thermothrix thioparus*, *Thiobacillus thermophilica*, etc.

## Applications of Microbial Leaching

### Copper Leaching

Copper leaching by biological method is practiced in several countries including USA, Chile, Australia, Canada, etc. *T. ferrooxidans* is used to leach out copper from the ore.

Copper ore extracted from mines is segregated. High-grade material is made to concentrate and introduced for smelting, while the lower grade ore is subjected for leaching. The ore is piled on an impermeable surface until a dump is accumulated up to 40 m height. After the top is leached, solution is flooded or sprayed onto the dump. Bacterial colonisation occurs in the top. The temperature may reach 90° C in the centre of the dump owing to exothermic nature of chemical reaction. Leach solution appears at the base of the dump and are transported to central recovery facilities. In most large scale operations solution contains 0.5 to 2 gms Cu to large units contains iron scrapes. The following reaction then occurs as follows:

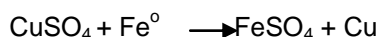

The finely divided cement copper is regularly recovered and refined for sale.

### Uranium Leaching

Uranium leaching using microbes was introduced recently. To initiate leaching process tile tunnels of underground mines are flooded with dilute sulphuric acid solution. Bacterial activity is limited to oxidation of pyrite and ferrous iron because *T. ferrooxidans* does not directly interact with uranium minerals. Uranium leaching proceeds according to the following reaction.

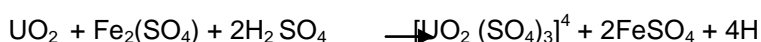

the uranium recovering ranges from 30 to 90%. The common yeast *Saccharomyces cerevisiae* and fungus *Rhizopus arrhizus* have recently been shown to adsorb uranium from the waste water. The surface binding of uranium is optimised and suggests that positively charged uranium ions are attracted to the negatively charged ligands on the cell.

### Leaching of Other Metals

Copper and Uranium are not the only metals that can be recovered by a microbial leaching process. The microbe *T. ferrooxidans* has been used in the leaching of cobalt, nickel and zinc. This leaching is indirect. Sulphuric acid is generated during sulphur oxidation by the microbe, thus leaching of all the metals is an acid solubilisation of metals. Microbial leaching of lead results in enrichment of lead in the metal matrix. During oxidation of galena (PbS), the lead is converted to insoluble lead sulphate besides, other soluble metal sulphates are also leached, leaving a concentrated lead product. This may be considered as a beneficial process.

### Leaching of Precious Metals

Recovery of precious metals like gold and silver from metal ores using microbial system is relatively a recent application. Gold ores are refractory when the precious metal is encapsulated by iron sulphide minerals. It is unavailable for contact with cyanide. Microorganisms degrade a surrounding matrix, allowing

contact between the lixiviant like cyanide and precious metals. Bacteria] leaching, of the common interfering pyrite and arsenopyrite is well

known. Research studies is not centered on the application of this process to specific gold. The comparison was made on gold recovery from cyanide and with bacteria. Interestingly, gold recovered was found to be greater than 90% when pretreated with T ferroxidans and it was only 50% with cyanide treatment.

Microbial pretreatment is an environmentally superior alternative to roasting. The roasting method generates air pollutants such as sulphur dioxide, volatile arsenic compounds and other deleterious compounds or elements. One pilot plant study showed greater gold recovery from microbial pretreatment than roasting. The economic viability of microbial pretreatment will be site specific and will depend primarily on the mineralogy of the ore.

### Metal Recovery by Microbial Accumulation

Either viable species or non viable microbial biomass can be used for recovery of metals from solutions. The living cells can be used to absorb or adsorb metals or by precipitating using metabolic end product. Certain type of microorganisms consist of *Pseudomonas maltophilia*, *Staphylococcus aureus* and corneform organisms accumulate over 300 mg silver grams per litre (dry wt.). This microbial community was stable and tolerated upto 100 mm silver. A mixed culture of *T. ferroxidans* and *T. thiooxidans* can accumulate silver as the mineral acanthite ( $Ag_2S$ ) during the leaching of sulphide minerals containing silver (Table 5).

Table 5. Leaching of metals by microorganisms.

Metal Sulphides	Leaching microorganisms
CoS	<i>Thiobacillus thiooxidans</i> <i>T. thiooxidans</i>
ZnS	<i>T. ferroxidans</i> <i>T. thiooxidans</i>
MoS	<i>Sulpholobus brieylegi</i> , etc.
Mis	<i>T. ferroxidans</i>

Removal of Heavy Metals: Effective heavy metal removal was observed in a series of lakes and streams that recovered sewage and effluents from mining. The presence of algae and sulphate reducing bacteria like *Desulfovibrio* sp., *Desulbo tomaculum* sp. and *Desulfbmonas pigna* in sewage was responsible for heavy metal removal. Sewage provides inorganic nutrients that stimulate algal growth. This leads to further metal removal through absorption on to biomass as sedimentation of the complex. Production of hydrogen sulphide and reducing conditions were primarily responsible for metal immobilisation in the sediments. This process can be proposed as method for concentrating heavy metal for secondary recovery.

### Biosorption

It is a passive metabolism-independent physico-chemical interaction between heavy metal ions and microbial surface. It is defined as 'a non-directed physico-chemical interaction that may occur between metal/radionuclide species and microbial cell. Most biosorption phenomena are combination of processes such as electrostatic interactions, ion exchange complexation, ionic band formation, precipitation, nucleation, etc.

These interactions occur due to complexity of microbial surfaces and chemical/physical properties of metal ions. For biosorption, active state of cells is not prerequisite. The process can occur even with inactivated/dead cells. Biosorption offers several advantages, for examples,

1. Process is not governed by physiological constraints of microbial cells. There is no need of costly nutrients for growth and aseptic operation of cells. It operates at a wider range conditions such as pH, temperature and metal concentrations.
2. Inactivated biomass works as an ion exchanger. Therefore, the process is rapid, for example *Streptomyces nouresei* carries out biosorption at a high speed (256  $\mu$  mol/g). Metals can be desorbed readily from the biosorbent and recovered.

### Organisms Involved in Biosorption

There are several microorcyanisms such as bacteria (*Arthrobacter viscosus*, *Pseudomonas sryngae*, *P. aeruginosa*, *P putida*, *Bacillus subtilis*, *E. coli*, *Streptomyces nouresei*, *S. pimprina*, etc.), fungi and yeast (*Saccharomyces* spp., *Aitreobasidium pullulans*, *R. nil-ricans*. etc.) and algae (*Chlorella vulgaris*, *Ascophyllum nodosum*, *Cladophora crispata*, etc.). Fungal mycelia (eg. *Aspergillus* and *Penicillium*) also

remove metals from wastewater and offer a good alternative for detoxification of effluents. Biosorption have shown that *Aspergillus oryzae* can remove cadmium efficiently from solution (Table 6).

Table 6. Fungi involved in metal removal from industrial wastewater.

Microorganisms	Metals removed
<i>Aspergillus nilger</i>	Copper, cadmium, zinc
<i>A. oryzae</i>	Cadmium
<i>Penicillium spinulosion</i>	Copper, cadmium, zinc
<i>Rhizopus arrhizus</i>	Uranium
<i>Saccharomyces cerevisiae</i>	Uranium
<i>Trichoderma vride</i>	Copper

### Bioextractive Metallurgy-Biomining - A Future Strategy

The microbiological processes currently exploited by the mineral industry are fairly simple in engineering design and their effectiveness is sensitive to seasonal changes and sudden alterations in the chemistry of the system. Current developments in the study of the uptake of metals by *S. cerevisiae*, *R. arrhizus*, and *P. aeruginosa* make it probable that these microorganisms can be utilized in precise processes for the recovery of metals from waste-water streams. The accumulation of metals by microbes, by whatever method, is nonspecific. Many organisms have cellular components that are highly metal specific. One of the best-understood metal binding agents is the protein metallothionein which is rich in sulphur containing amino acids forming a sulphhydryl (HS) chelation site. In the marine *cyanobacterium Synechococcus* a comparatively small cadmium binding metallothionein can bind an average of 1.28 atoms of cadmium per molecule of protein. Recent progress in the genetic manipulation of microorganisms for industrial purposes is likely to scale up the leaching processes in metal bearing ores as well as metal contaminated waste waters.

The important future programming in bioextractive metallurgy include (i) microbial genesis of sulphur from sulphate or of methane from organic residues in natural environments, (ii) immobilization or volatilization of polluting toxic elements such as arsenic or mercury (iii) microbial desulphurization of coal (iv) microbial removal of methane from coal mines (v) Use of aliphatic hydrocarbon-utilizing bacteria in detecting petroleum deposits including microbial processes for obtaining petroleum products from oil shale and tar sands (vi) microbial processing and removal of pyritio impurities from pottery clay (the problem is quite serious in Kerala in India). (vii) Immobilization of manganese and recovery of manganese and radium from the tailings through the use of microorganisms using bioaccumulation or accretion or bioconversion.

The natural property of several microbes to accumulate high intracellular concentrations of several metals is being investigated for water purification. Natureal cleaning cleaning symptoms are attracting serious attention for microbial extraction of metals from highly polluted sytreams and dump fields. Therefore , microbial extractive metallurgy has a potential role to play in both discovering and recovering wanted metals and resources and eliminating unwanted metals.

The important programme in bioextraction metallurgy includes

1. Effective microbial desulphurization of coal.
2. Microbial removal of methane from coal mines.
3. Immobilisation of pollutants of toxic elements such as arsenic or mercury.
4. Microbial process and removal of pyrite impurity from pottery clay.
5. Methane from organic residue waste.

Based on laboratory studies done by many researchers on current applications in the field, it is clear that microorganisms and the diversified activities will help to lay claim to mineral wealth buried deep in the ground. These small servants of man promise to help in changing the air and water, leaching valuable metal resource.

### Advantages of Biomining

1. Bioleaching of metals from ores requires only a little energy.

2. It is economic.
3. It well suited for lower grade ores and tailings.
4. It can be carried out inside the mine and outside the mine.
5. It does not pollute the environment.

### **SHORT QUESTIONS**

1. Biofuels
2. Gasohol
3. Bioleaching
4. Methanogens
5. Marsh gas
6. Gobar gas
7. Methane fermentation
8. Methanogenic bacteria.
9. Methane production from hydrocarbons
10. Biogas
11. Anaerobic degradation
12. BOD
13. Bioremediation processes
14. In situ bioremediation
15. Ex situ bioremediation
16. Land farming
17. Microbial Enhancement of Recovery (MEOR)
18. Recovery of oil by injecting microbes
19. Mining or biomining
20. Microbial Leaching or bioleaching
21. Metal reclamation
22. Biohydrometallurgy
23. Intrinsic bioremediation
24. Engineered bioremediation
25. Bioremediation of hydrocarbons
26. Composting
27. Bioaugmentation
28. Biostimulation
29. Microbial leaching (bioleaching)
30. Thiobacillus ferrooxidans
31. Copper leaching
32. Uranium leaching
33. Metal recovery by microbial accumulation
34. Bioextraction metallurgy
35. Biosorption
36. Super bug.

**QUESTIONS**

1. Explain the biological fuel generation.
2. How ethanol is produced in Industry?
3. Discuss the applications of Ethanol.
4. Describe the methane production from biomass.
5. Explain the biochemistry of methane formation.
6. List out the uses of methane biogas.
7. What is biogas ? Give a detailed account of biogas technology in India.
8. What are the feed stock materials used in biogas production? Discuss in brief any one of them used in biogas production.
9. What are the sources of methane used as gaseous fuel? Discuss its future importance.
10. Write an essay on liquid fuels.
11. Describe the biological treatment of wastewaters
12. 5. Explain the sewage treatment.
13. What is biogas ? In what ways biogas can be produced on sewage.
14. Comment on the immobilisation technique in waste water treatment.
15. What is bioremediation? In what ways it is good tool for environmental clean-up ?
16. Write an extended note on in situ bioremediation with examples.
17. Write an essay on ex situ bioremediation with special reference to composting.
18. What is biosorption? Write organisms used in biosorption technologies.
19. Discuss in detail slurry-phase treatments by using different approaches.
20. What are the industrial wastes ? Write in detail their bioremediation methods.
21. Discuss the use of microorganisms in recovery of metals from mines.
22. What is Bioleaching? Discuss the mechanism of bioleaching of ores by microbial action.
23. What do you know about bioleaching? Write in detail bioleaching of copper by giving methods and mechanisms of bioleaching.

## 4. PLANT AND ANIMAL BIOTECHNOLOGY

- 4.1. Applications of DNA Technology in Agriculture
- 4.2. Applications of DNA Technology in Animal Husbandry
- 4.3. Development of Transgenic Plants
- 4.4. Development of Transgenic Animals
- 4.5. Basic Principles and Applications
- 4.6. The Human Genome Project

Agriculture as such is usually excluded from the definition or jurisdiction of biotechnology, but genetic manipulation of crop plants and their tissue form important parts of modern biotechnology. Developments in biotechnology can have widespread effects on our agricultural progress, in such areas as plant breeding, plant protection, and animal improvement.

The application of biotechnology has potential to improve agricultural production and aquaculture to meet the demands of a growing population in the next century. Now agricultural developments in the next century must therefore be sustainable; they should meet human needs, be environmentally-friendly and conserve non-renewable resources.

For at least 10 centuries, farmers have been producing better crops simply by saving the seeds of good quality plants, but during the past century, plant breeding has become more rigorous in its approach. Genetic engineering is now a promising method of developing superior plants. By using recombinant DNA techniques, it is possible to move specific and useful segments of genetic material between unrelated organisms. This approach adds some diversity to the sum total of traits from which the plant breeder can choose.

### 4.1. APPLICATIONS OF DNA TECHNOLOGY IN AGRICULTURE

Combining DNA from different existing organisms (plants, animals, bacteria, etc.) results in modified organisms with a combination of traits from the parents. The sharing of DNA information takes place naturally through sexual reproduction and has been exploited in plant and animal breeding programs for many years.

What's new since 1972 is that scientists have been able to identify the specific DNA genes for many desirable traits and transfer only those genes, usually carried on a plasmid or virus, into another organism. This process is called genetic engineering and the transfer of DNA is accomplished using either direct injection or the *Agrobacterium*, electroporation, or particle gun transformation techniques. It provides a method to transfer DNA between any living cells. Virtually any desirable trait found in nature can, in principle, be transferred into any chosen organism. An organism modified by genetic engineering is called transgenic.

A **transgenic animal or plant** is one that has a foreign gene (called a "transgene") inserted into its DNA. Transgenic plants are sometimes called genetically modified organisms (GMO) or transgenic plants.

A **transgene** is the foreign gene that has been moved from one organism into a new organism by genetic engineering. For example, a bacterial gene that is inserted into a plant's DNA would be a transgene

In traditional **plant breeding**, a plant with a desired trait is crossed with an existing plant to transfer the desired trait to the offspring. Of course, the only genes that are involved are the genes already present in the parental plants.

Progress is being made on several fronts to introduce new traits into plants using recombinant DNA technology. The genetic manipulation of plants has been going on since the dawn of agriculture, but until recently this has required the slow and tedious process of cross-breeding varieties. **Genetic engineering promises** to speed the process and broaden the scope of what can be done.

There are several **DNA technology** applied for introducing genes into plants.

#### 1. Improvement of Hybrids

Developments of cell fusion and hybridization techniques are useful in the production of new varieties within a short time. Kuchko (1985) obtained somatic hybrid of wild and cultivated **potatoes** (*Saccharomyces tuberosum* and *S. chacoense*). The **somatic hybrid plant** inherited many characters viz.,

intermediate leaf morphology, prolonged flowering, large and fertile pollen grains, high yield, and resistance against  $\gamma$ -virus.

The best example of the application of **anther culture** in crop breeding and improvement is the production of anther culture derived rice and wheat varieties in China. About 50 varieties in rice and 20 in wheat have been developed by using this technique. The advantages of anther culture as a tool in plant breeding are cell and tissue culture systems are currently being evaluated for the use in transfer of foreign genetic material to select plant species by protoplast fusion, transformation, transduction and organelle transfer.

## 2. Encapsulated seeds

T. Murashige of the U.S.A. for the first time gave the concept production of artificial seeds. Artificial (encapsulated) seeds are the somatic embryos covered with I protecting gel. In these seeds, the gel acts as see coat and artificial endosperm providing nutrient as in true seeds. Water soluble gels (hydrogel) are used as the protective gel. Usually Na/Ca alginate (a product of brown algae) is used for encapsulation purpose because it is less toxic to embryos and easy to handle.

Kitto and Janick (1985a) produced *Citrus* embryos *in vitro* and tested 8 compounds for their synthetic coating properties on embryos. Out of the chemicals tested, a polyethyleneoxide (polyox WSR-N75) revealed good encapsulating properties. It was selected for use in further research with *in vitro* produced carrot embryos. Later on Polyox coated embryos were kept in dry condition and then allowed for germination at suitable conditions. The germination percentage of the encapsulated embryos was low. The uncoated embryos did not survive after dry treatment. (i) Kitto and Janick (1985c) applied a number of presumptive hardening treatments OZ., high inoculum density (0.8 embryo suspension per 25 ml medium), (ii) 12 per cent sucrose instead of 2 per cent (iii) chilling at 41° C during, the last three days of the embryo induction phase, and (iv) amending 1 $\mu$ m abscisic acid in the nutrient medium at the time of embryo induction. These treatments should be combined with **polyox coating**. All the treatments increased the viability of the coated embryos. Similarly, production of artificial seeds by encapsulation of matic embryos in *Eucalyptus* sp. has been reported by Muralidharan and Mascarenhaus (1987). **Synthetic seeds** of *Selinum tenuifolium* (bhutkeshi) produced by using somatic embryos.

## 3. Production of Disease Free Plants

Many plant species, which propagate vegetatively are systematically infected by virus, bacteria, fungi, and nematodes. Disease free plants can be produced by tissue culture techniques. Their inoculum is carried over several generations resulting in continued adverse effect of productivity and quality of crops. In order to ensure highest possibly yield and quality it is necessary to **provide disease free (resistant) stock** plants to growers. Tissue culture techniques have the problem and minimized the time of biological testing. Unless large scale population of pure inoculum of test pathogens are available, it is difficult to pursue the establishment of pathogenecity and crop loss – assessment. It is done in field condition. Now it has become possible to carry out such experiments in laboratory within short span of time by using tissue culture technologies. Miller and Maxwell (1983) have: discussed the following advantages for the study of several aspects of host-pathogen interaction and responses:

### Production of Virus Free Plants

About 10 per cent of viruses transmit through seeds. In some cases, they are confined to seed coat (e.g. TMV) or internally seed-borne (in legume). Moreover, viruses result in great loss, for example, potato leaf roll virus or potato virus X can cause upto 95 per cent reduction in tuber yield and potato virus X between 5 and 75 per cent depending on virus strain and host cultivar.

**Tissue culture technique** can be utilized for the production of virus-free plants either through meristem culture or chemotherapy or selective chemotherapy of larger explants from donor plan: or dormant propagates or a combination of the two. Above plants were made virus-free by meristem culture.

**In vitro selection of cell lines for Disease Resistant:** For the study of disease i-ance *in vitro*, one of the important considerations is the selection of suitable type of culture e.g. callus tissue, suspension culture, isolated cells or protoplasts. However, callus cultures have been widely used for study of expression of race-specific and non-host resistance, and offer several advantages over suspension cultures, isolated cells or protoplasts. The advantages are: (i) ease of initiation and maintenance of tissue in culture, (ii) ability to add inoculum (spores and zoospores, etc.) directly on callus surface so that the culture medium does not act as direct source of nutrients for the pathogen, (iii) the ability to follow the progress of infection and colonisation of callus tissue by the pathogen using histological/cytological methods, and (h) phytoalexin accumulation can be determined in pathogen challenge tissue and related to the extent of colonization.

## 5. Transfer of nif gene to Eukaryotes

**Nitrogen fixing ability**, a genetic character, exists in prokaryotic diazotrophs. However, one major task is the transfer of this character to eukaryotes. In recent years, researches are done to solve this problem through tissue culture techniques coupled with the recombinant technology. Historically, nitrogen fixation by rhizobia was believed to occur through symbiosis. The first time an excitement was caused in scientific community with the discovery by Holsten (1971). They obtained active rhizobia in the absence of nodules, leghaemoglobin and bacteroids were apparently necessary in the intact plants. They established *Rhizobium japonicum* on suspension of soybean roots. Callus induced from root explants of soybean on a specific kim was inoculated with *R. japonicum*. Later on it was microscopically observed that infection ails were formed by the bacteria which were present between intracellular spaces. They multiplied inside cells. Moreover, **development of nitrogenase** in soybean callus *Rhizobium* system growing on solid medium was also observed by Child and La Rue (1974). It was found that only specific (isomorphic) cells of callus are vulnerable to infection by the bacteria.

In addition to improvement in the bacterial strains and increased nodulation, it is necessary to seek those genotypes with the **efficient photosynthesis** and improved partitioning of carbohydrates in nodules.

The real challenge lies in achieving greater input of biologically fixed nitrogen into nonlegume crops. Improvement of associative  $N_2$  fixation by sugarcane, wheat and the crops associated with *Azospirillum* have the same objective as *Rhizobium* works. They have been clones, for example. (i) phaseolin and leghaemoglobin genes of soybean, (ii) storage protein genes in soybean, (iii) genes of ribulose biphosphate carboxylase/oxygenase (Ru BP case) of pea, maize, wheat etc. Success achieved on these aspects would certainly promote in **green revolution**.

### Selective Gene Breeding

DNA Technology is widely used for selective breeding in domestic animals, saving many generations of breeding to get desired characteristics. Moreover, with some species, the young totipotent embryo can be "teased" apart so that one zygote can be used to make a dozen identical offspring. With gene selection, the insertion has to be at a gene locus that can be "read" and must be inserted into gametes or at least into the target tissue area to be useful. In addition, the inserted gene cannot disrupt normal activity. Since there is little control over where the gene gets spliced into the host egg cells, mutant or transgenic animals often have a low survival rate.

### Plant Applications of DNA Technology

*Agrobacterium tumefaciens*, a natural tumor-causing bacterium of plants, is the host bacterium for much DNA technology in plants. The tumor genes are removed, and a highly modified plasmid, the *Ti* plasmid, incorporates desired new genes, along with the needed promoter, and post transcription processing genes (Fig. 21). The altered *Agrobacterium* "infects" a tissue-cultured plant, which may express the inserted genes normally. Unfortunately, *Agrobacterium* only infects dicots.

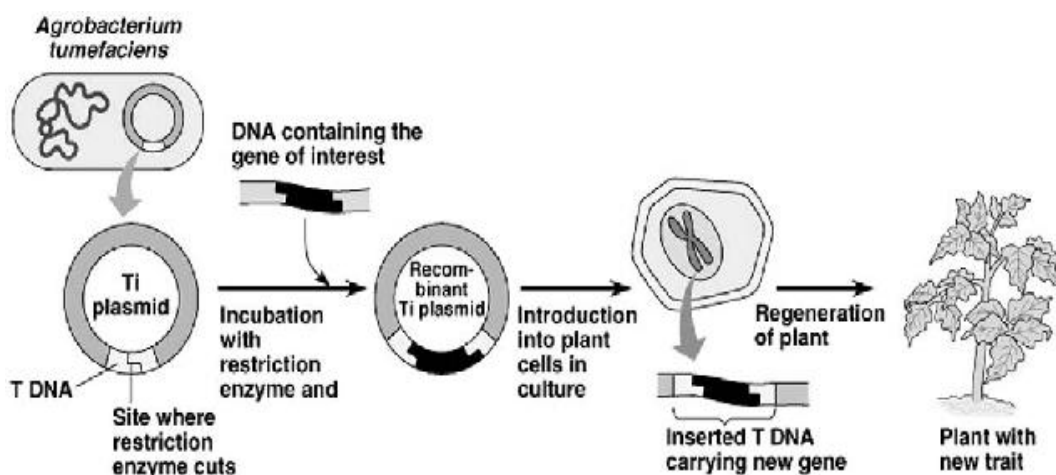

Fig. 21. Genes can also be "shot" directly into plant cells with a "DNA gene gun". The gene gun injects coated DNA particles into the target plant cells.

DNA technology has been used to help plants be resistant to frost, saline soils, wilting, herbicides such as round-up, and insect pests. Genes have been altered to delay maturation and to increase nutrient content.

## 4.2. APPLICATIONS OF DNA TECHNOLOGY IN ANIMAL HUSBANDRY

**Animal Husbandry** are the breeding, feeding, and management of animals for the production of food, fibre, work, and pleasure. Intensive husbandry conditions include large numbers of animals in small pens or cages, enriched feed, growth stimulation by various means, and vaccination against disease. Most of the world's domestic animals, however, are raised in small units under less efficient conditions and at lower rates of return. For long, animal **breeders have strived to improve productive performance traits, such as growth, milk yield and feeding efficiency. Genetic improvements** have greatly increased the economic efficiency of many domestic animals, mainly due to the application of quantitative genetics.

Modern biotechnological tools like **artificial insemination, cloning, in vitro fertilization, embryo transfer, gene splicing and gene injection** are used to manipulate the DNA, but also to engineer in other ways living organisms for specific purposes. **The recombinant DNA technology includes the following techniques.**

### Artificial Insemination and Germ Cell Storage

Muller (1927) has suggested that techniques should be evolved to store germ cells in vitro for future use. He suggested that sperms and eggs be collected from people who have been adjusted superior by common consent. These germ cells are kept viable in cold storage. As early as 1930, animal physiologists extensively studied the origin and behaviour of germ cells in pigs, sheep, cattle and poultry.

**Artificial insemination and germ cell storage are techniques**, which have come to stay their use in animal breeding having resulted in enormous advantages. In artificial insemination, semen is diluted and stored at 40°C and can be used for 4 to 5 days. The unused semen is to be discarded. The storage temperatures were gradually lowered and it was found there was a limit to this lowering, because at very low temperature, the sperm heads are disrupted owing to crystallization on the contents and the sperms died. However, a simple alteration in constitution of the diluents such as the addition to glycerol, prevented damage to the sperm head. It permitted refrigeration of diluted sample to very low temperature using special refrigerant liquid nitrogen. This technique is known as the **deep-freezing technique**. It is the ability to store spermatozoa for prolonged periods of time by deep-freezing has also enabled the transfer of valuable genetic material between countries and provided a unique method for genetic conservation. We still need a improvement in the methodology for low temperature **preservation of semen in order to enhance fertilizing capacity.**

**Artificial insemination** has the greatest impact on animal breeding, particularly in cattle and, when The ultimate goal for artificial insemination technology is to **develop methods for sexing semen** by the separation of spermatozoa into populations of those bearing either an X or Y chromosome thus permitting the preselection of the sex of animals at the time of fertilization.

### Cloning Technique

Cloning is a method by which a number of **genetically identical organisms are derived from a single organism by vegetative propagation**. Cloning is simple technique. The nucleus of mature unfertilized ovum may be removed either by surgery or by irradiation. It can be replaced by a nucleus from any body cell of the adult organisms belonging to the same species. The adult cell may come from the skin, intestines or the respiratory tract. The egg cell will now develop as it had been fertilized, and eventually yield an organism, whose genetic constitution will be similar to the parent. Reproduction through cloning has been very successful in plants, where thousands of genetically uniform offspring may be obtained from any one plant. Cloning has also been used with success in frogs, salamander and *Drosophila*. The significant feature in cloning is that all the cells of an alone are in identical with one another and with the parent cells.

### In vitro Fertilization and Embryo Transfer

**Embryo transplantation** is a technique that has been developed more recently. It provides a means for exploiting the genetic potential of the female rather than the male. The procedures can be applied effectively in most of the large domestic species. It gives us another dimension to the opportunities for artificial breeding and **livestock improvement**.

In various parts of the world, many commercial companies are actively working for **embryo transplantation** and developed the skill in this field. In **in vitro fertilization**, eggs are fertilized outside the body of the mother in glass vessels for subsequent reintroduction into the womb. For this purpose, **egg production is stimulated in the mother using hormones or fertility drugs**. This often results in the recovery of more than one egg simultaneously, thus increasing the chance of establishing pregnancy. After treatment with fertility drugs, a laparoscopy is performed on the woman through a small opening in the abdomen and ripe follicles can then be visualized. These follicles are ruptured and the eggs collected by suction through a tube into a glass vessel containing the culture medium. A fresh sample of semen is obtained from the male about an hour before the eggs are collected. The sperms are washed twice and

centrifuged in the culture medium before they are mixed with the eggs. A concentration of 100,000 to 80,0000 motile sperms is needed for successful fertilization.

When the eggs complete their maturation process, they are kept in the culture medium, for 5-6 hours before they are mixed with sperm. At the end of this period, sperms and eggs are mixed together. After 30 hours, the fertilized eggs may form 2 celled embryos; at about 40 hours the embryos may be 4 celled and at about 60 hours 8 celled. In **embryo transfer**, any embryo from the one celled to the 16 celled stage may be used. Through a narrow catheter passed through a cervix into the uterus, the embryo is transferred. This is a simple, safe and painless procedure needing no anesthesia

*In vitro* fertilization and embryo transfer are at present used for both diagnostic and therapeutic purposes. They are mainly used in the case of women reporting with infertility. Sometimes embryo transfer fails and it would seem advisable therefore to collect as many **eggs** as possible at the same time and have them fertilized. Then use one **or two for transfer into the woman and store the rest in a frozen state for future use.**

### **In vitro Fertilization and Embryo Transfer for Improved Breeding Programmes**

Biotechnological advances have been made during the last few decades in the field of artificial breeding and the control of animal reproduction with special reference to, artificial insemination, superovulation and embryo transplantation (Fig. 1), methods for the of estrus cycles, techniques for

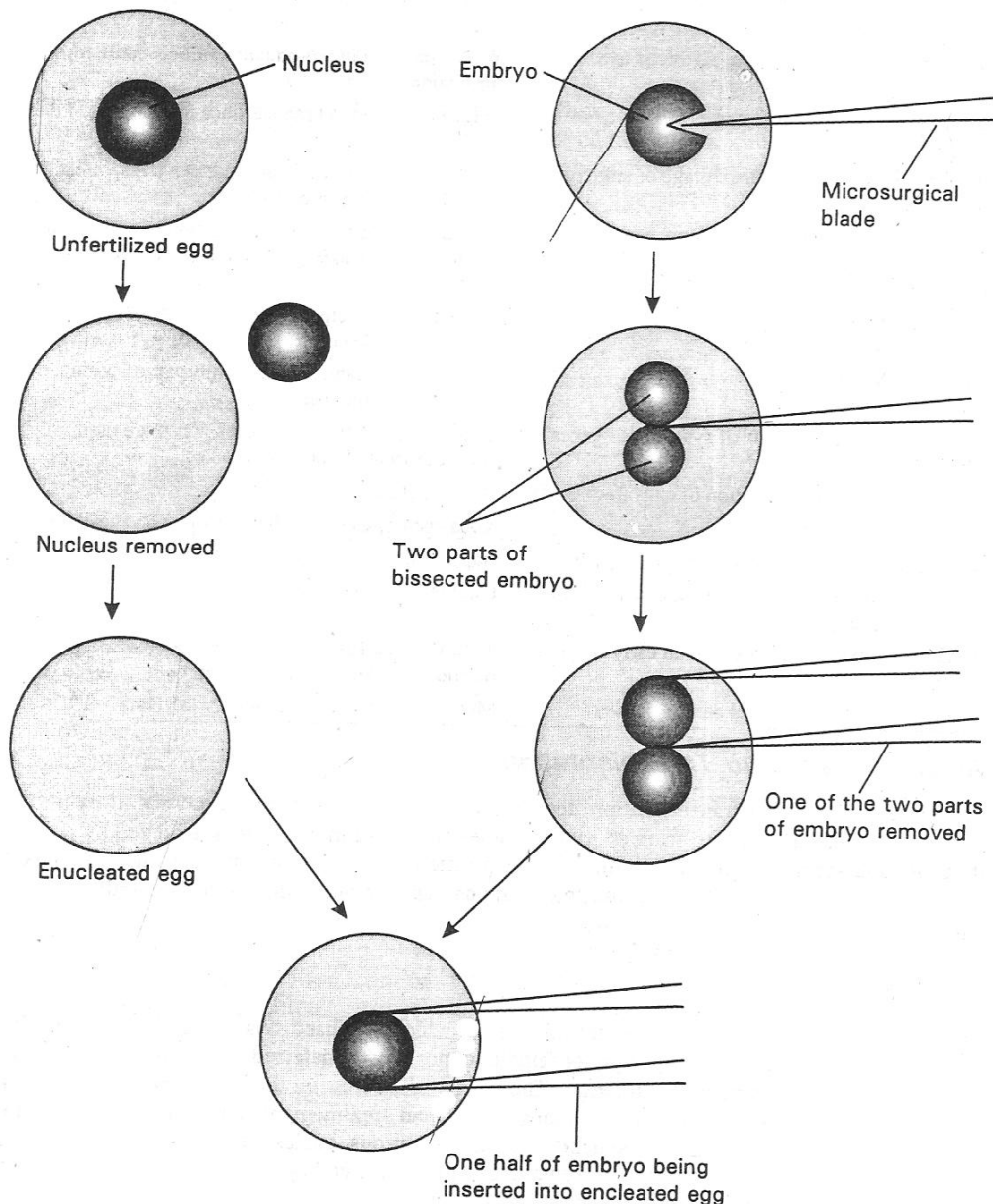

Fig. 22. Splitting of an embryo followed by transfer of one half of the embryo to an unfertilized egg whose contents were removed.

increasing prolificacy, induced parturition and early pregnancy diagnosis, etc. These techniques have provided new opportunities for the improvement of livestock production. This technique is probably the solution to all problems in **animal breeding**. How these improvements would take place and what the relative likelihoods of increasing rates of PTO gross? Biotechnological procedures are used for the ability to collect, freeze and store bull semen to use by artificial insemination (AI) and more recently, the ability to **freeze and store cattle and sheep embryos**. Indeed, the whole structure of selection programmes can be changed by the use of such techniques. Embryo transfers technique can increase beef production by more than 50 per cent. Nicholas and Smith (1983) show that the use of Multiple Ovulation and Embryo Transfer (MOET) techniques can double the rate of progress in dairy cattle. The ability to clone by the micromanipulation of embryos increases the selective capacity available to animal breeders.

### Success of Embryo Transplantation

The success of embryo transplantation depends largely upon the ability to obtain an **increased number of embryos from animals** of superior genetic merit. This is achieved by the use of exogenous gonadotrophic hormones such as purified **follicle stimulating hormone** or pregnant mares' serum gonadotrophin administered at an appropriate time for the **induction of superovulation**.

### Embryo Transfer

Embryo Transfer (ET) refers to the techniques by which fertilized ova are collected from the reproductive tract of a genetically superior female (donor) and transferred to that of another female (recipient) which is genetically inferior. The chain of events in the entire process includes selection of donor and recipients. The management and treatment of donor for production of optimum number of viable ova, synchronization of estrous cycles of donor and recipients, breeding of the donor with quality (proven/pedigreed) semen, embryo collection from the donor, evaluation of embryos and transfer to suitable recipients (Fig.22).

### Gene Injection (introduction of Foreign Cloned Genes)

An area of active experimentation now concerns the introduction of foreign cloned genes into mammalian eggs and the production of transgenic animals. In mice, it has been found that one of the most effective methods for the introduction of DNA into the genome is by microinjection of cloned genes directly into the male pronucleus of an egg shortly after fertilization Fig. 23. The foreign genes may then become incorporated into the chromosomes during early development and following transplantation of the eggs produce transgenic animals. In some animals the genes may become stably integrated and expressed and be transmitted through the germ line.

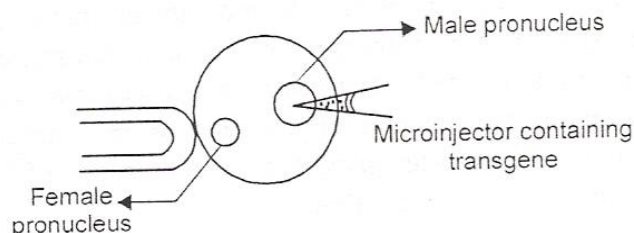

Fig. 23. Microinjection of foreign DNA into a fertilized egg for production of transgenic animals.

### Dense Cytoplasm and Gene Injection

In the eggs of most farm animals, however, the cytoplasm is too dense to be able to visualise the pronuclei for the purpose of microinjection. For pig eggs, however, this problem has been overcome by centrifuging them so that the opaque cytoplasm is concentrated to one pole and the pronuclei then become readily visible under the microscope.

Now the efficiency of **gene transfer** is very low and large number of eggs must be injected to obtain a positive result. Much remains to be learned about the types of gene constituents, which will enable optimal integration into the genome, result in tissue specific expression and produce animals with a desired phenotypic response. The identification of genes for characteristics of special economic importance is also a major area of experimentation. Nevertheless, the possibilities for genetic engineering by recombinant DNA technology opened new vistas for the future.

### Genetic Engineering- Single Genes

It is now possible to identify single genes, which have major performance effects and to transfer from some species to those to whom the benefit would be greatest without taking with the attribute the accompanying undesirable genes. This helps us to eradicate certain genetic problems and to establish gene

libraries. The animal breeder is to consider this gene transfer as a special case of migration and initially has to ask what the potential genes are for transfer for use in this particular way.

In animal production, the whole system and the whole animal should be taken into consideration, rather than with the constituent processes and parts involved in production. The **pleiotropic effects** of genes cannot be ignored in any of the assessments of production systems and the evaluation of any genetic engineering must be in terms of the total influence of the system, not on an especially dramatic change in one particular character. The important overall consideration must be the production efficiency of a high quality product.

### 4.3. DEVELOPMENT OF TRANSGENIC PLANTS

The plants, in which a functional foreign gene has been incorporated by any biotechnological methods that generally not present in plant, are called **transgenic plants**. However, a number of transgenic plants carrying genes for traits of economic importance have either been released for commercial cultivation or are under field trials.

There are several methods discussed in previous chapters which are used in **gene transfer**. These includes: (i) electroporation. (ii) particle bombardment, (iii) microinjection. (iv) *Agrobacterium* mediated gene transfer, (v) co-cultivation (protoplast transformation) method. (vi) leaf disc transformation method, (vii) virus-mediated transformation, (viii) pollen-mediated transformation. (ix) liposome-mediated transformation, etc.

During the last 20 year, considerable progress has been made on isolation. characterisation and introduction of novel genes into plants. As per estimate made in 2002, transgenic crops are cultivated world-wide on about 148 million acres (587 million hectares) lands by about 5.5 million farmers. Transgenic crop plants have many beneficial traits like insect- resistance, herbicide tolerance, delayed fruit ripening, improved oil quality, weed control, etc.

Currently, India is importing both grain legumes and edible oils to meet people's demand. By 2050, India's population is expected to reach about 1.5 billion. It is hoped that 30% India's population will be suffering from malnutrition. Therefore, nutritional security for everyone would require the extensive availability of grain legumes, edible oil fruits and vegetables, milk and poultry products. These challenges can be met by better resource management, producing more nutritious and more productive crops.

To strengthen further research in the area of crop biotechnology a new institute, the National Centre for Plant Genome Research (NCPGR) has been established in New Delhi to strengthen plant biotechnology research in India. Department of Biotechnology (DBT) (Ministry of Science & Technology) has made enough funds for promotion of crop biotechnology.

So far more than 60 transgenic dicot plants including herbs, shrubs and trees and several monocots (*e.1a. maize, oat, rice, wheat, etc.*) have been produced. In future, the number of these crops certainly will go up. These transgenic plants contain certain selected traits such as herbicide resistance, insect resistance, virus resistance, seed storage protein, modified ripening, modified seed oil, a-alutinin, etc. Moreover, in the light of future need, the transgenic plants are being looked up as bioreactor for molecular farming *i.e.* for the production of novel biomedical drugs such as growth hormones, vaccines, antibodies, interferon, etc.

#### Herbicide resistance

A soil bacterium gene that is resistant to glyphosate (RoundUp, the most commonly used herbicide) has been introduced into a number of dicot crop plants using the Ti plasmid, notably soybeans. Glyphosate interferes with aromatic amino acid synthesis in chloroplasts, stopping cell growth.

#### Nitrogen Fixation

Plants that can fix their own nitrogen require less fertilizer and enhance soil. However, no plant fixes nitrogen. Some plants have associations with bacteria or cyanobacteria that fix nitrogen, most commonly in root nodules of the host plant. Nif genes in the bacteria convert  $N_2$  to  $NH_3$ , and enzymes within the plant tissues convert the  $NH_3$  to amino acids. Unfortunately, the genes cannot be spliced into eukaryotic cells.  $O_2$  (essential for cell respiration in the plant cells) interferes with the bacterial nitrogenase enzymes that convert the  $N_2$ .

#### Insect Resistance

About 40% of the insecticides produced are used on cotton alone to protect cotton against boll weevils and other cotton pests. The bacterium, *Bacillus thuringiensis* (BT), produces a protein that gets converted to a toxin in the intestines of Lepidopteran larvae, killing the larvae. The enzymes that convert

the protein are specific to Lepidoptera. The genes that code for the protein have been incorporated into cotton, corn and potatoes. This has greatly minimized the need for some pesticides. BT has been engineered into strains of bacteria (*Pseudomonas*) that invade root tissue, so that roots also have protection against larval pests. Desiccated *Bacillus thuringiensis* has been used for years as a pesticide. Its viability is low, degrading rapidly once applied, so many applications must be made during the growing season.

The enzyme, cholesterol oxidase, disrupts insect gut membrane activity. The Bollgard gene that codes for the enzyme has been isolated from a fungus, and has been used in potatoes and cotton in field testing.

### **Frost Resistance**

A common bacterium, *Pseudomonas syringae*, which lives on the epidermis of plant leaves and stems, causes ice crystals to form at temperatures above freezing. This bacterium has been genetically altered so it cannot make ice crystals; therefore plant surfaces do not freeze until lower temperatures are reached, an agricultural bonus.

### **Delayed Maturation**

Tomatoes (the "Flavr Savr") that have delayed maturation can be harvested and transported more readily, and have a longer shelf life.

### **Fungal Resistance**

Another altered bacterium helps elm trees resist Dutch elm disease (which is caused by a fungus).

### **Improved Nutritional Quality**

As mentioned with golden rice, genes that enhance nutrient content can be added to a crop plant. Enhancing protein quality is one goal by increasing the proportion of amino acids that are using low in plants.

### **Plants as Vaccine Vectors**

It is hoped by some to introduce vaccines into fruits or vegetables, so that obtaining immunity would be easier than it is today. Dutch researchers have incorporated a vaccine against dog parvovirus into petunia, where the gene gets expressed in nectar producing cells. Bees collect the nectar, and the vaccine is extracted from their honey, demonstrating the feasibility of plants expressing the needed vaccine.

### **Gene Expression in Transgenic Rice**

In rice, after **co-electroporation** of DNAs encoding a selectable marker and the gene of interest, protoplasts are regenerated to yield fertile plants. To date, more than 50 different genes of interest have been successfully introduced and their patterns of expression are being studied (Hemming, 1993). Constructs containing a coding region of arcelin, a bean seed protein with insecticidal properties, and others containing viral sequences that may provide novel approaches for protection against virus infection, have been introduced into rice plants.

### **Resistance to Insect pests**

In recent years, several crop plants have been genetically modified for improved resistance to insects and viruses. The plants have been endowed with genes that give them a survival edge in the field. But for many important crops, including cereal grains, beans and peas, the danger from pests doesn't end with the harvest. Weevils and other insects often cause heavy losses during storage. In many developing countries, farmers cannot afford protective chemical fumigants. Biotechnology has potential to combat pests in the storage bin as well as in the field. **A strain of garden pea** has been created in Australia that resists attack by two weevil species (the colapea weevil *Callosobruchus inaculatus* and the Azuki bean weevil *C. chinensis*).

### **Virus resistant transgenic plants**

Plant viruses cause severe disease on crop plants and result in yield loss in several economically important plants. . Viral infection does not take place in plants already infected with certain viruses. This principle is called **cross protection**. By using this principle plant, genetic engineers have been developing transgenic virus resistant plants.

### **Transgenic Plants Resistant to Fungi and Bacteria**

**Brogie et al.** (1991) have introduced chitinase gene of beans into tobacco and oil seed rape. The transgenic plants are resistant to the fungal pathogen ***Rhizoctonia solani***, causing damping off of

seedlings. Chitinase gene of the soil bacterium *Serratia macescens* was introduced into tobacco. The transgenic tobacco is resistant to *Alternaria longipes*, causing brown spot disease.

A team of scientists in California introduced bovine *lysozyme gene* into tobacco calli through Ti plasmid. The transgenic tobacco produces bovine lysozyme that destroys the cell wall of invading pathogenic bacteria. As the plant cells destroy bacteria, the plants can resist the bacterial pathogens.

**Transgenic Plants With Bt Toxin:** The *Bt* gene of a bacterium, *Bacillus thuringiensis* has been found to encode the toxins called endotoxin which pose lethal effect on certain insect pests. These toxins are of different types such as beta-endotoxin and delta-endotoxin.

Several transgenic crop plants have been developed and commercialised at national and International levels (Tables 7). However, many transgenic plants are under field trials.

Table 7. Transgenic plants which have been produced by using recombinant DNA technology by inserting valuable traits.

Traits	Plants
Herbicide resistance	Corn, cotton, oilseed rape, potato, tobacco, tomato
Insect resistance	Corn, cotton, oilseed rape, potato, tobacco, tomato
Virus resistance	Corn, cucumber, melon, papaya, potato, tobacco, tomato
Modified seed storage	Sunflower, rice, soyabean, Protein
Modified ripening	Tomato
Modified seed oil	Oilseed rape
Agglutinin	Corn (wheat germ)

Similarly, **transgenic tomato plants** have also been produced through cell/tissue culture and transformation techniques.

In 1996, the first two companies gene and Ciba insect resistant seeds of corn which has shown very effective protection from the European corn borer.

### Molecular Farming from Transgenic Plants (Bioreactor)

Animal life is possible due to plants. Plants are the natural producers. Plant cells act as the natural's cheapest 'factory'. The cell uses CO<sub>2</sub>, water, minerals and sunlight to synthesise thousands of valuable and complex products which are the basis of animal's life.

In recent years, transgenic plants are used by biotechnology industries as 'bioreactor' for manufacturing special chemicals and pharmaceutical compounds. Normally these chemicals are produced in low amount or not produced by the plants. Bioreactors are culture vessels used for large scale production of some valuable products from microbes. Similarly, some transgenic plants are also used for the large scale production of certain products. Hence, they are believed to be **transgenic plant bioreactors**. They are used to **produce vaccines, interferons, biodegradable plastic**, monoclonal antibodies, functional antibody fragments, proteins, vitamins and the polymer polyhydroxybutyrate (PHB), etc. The transgenic plants can be grown anywhere using organic manure. There is no need for costly chemicals, equipments and skilled staff. The proteins, which are too expensive to produce in microbial processes can also, be obtained from transgenic plants without much expense.

### Nutritional quality

Nutritional quality of plants can be improved by introducing genes. Transgenic plants have been produced that are capable of synthesizing cyclodextrins, vitamins, amino acids, etc. Consumption of such plant will help in improving the health of malnourished people in poor countries. In this context, some examples are given below.

**a. Cyclodextrins:** Cyclodextrins (CD) are cyclic oligosaccharides containing 6, 7 or 8 glucose molecules in  $\alpha$ ,  $\beta$  and  $\gamma$  linkage respectively. CDs are synthesised from the starch by the action of Cyclodextrin glucosyl transferase (CGTase) enzyme. It is used in pharmaceutical delivery system, flavour and odour enhancement and removal of undesirable compounds (e.g. caffeine) from food. ACGTase gene isolated from *Klebsiella* was transferred successfully into potato. The transgenic potato tubers produced CDs.

**b. Vitamin A:** Vitamin A is required by all individuals as it is present in retina in eyes. Deficiency of vitamin A causes skin disorder and night blindness. Throughout the world 124 million children are the sufferers of vitamin A. Each year about 20 million new children are victimised due to deficiency of vitamin A.

You know that rice is used as staple food almost in every country. The contents of vitamin A is very low in rice. Vitamin A is synthesised from carotenoid which is precursor of vitamin A. Carotenoid is synthesised by three genes. Prof. Ingo Potrykus and Peter Beyer produced genetically engineered rice by introducing three genes associated with biosynthesis of carotenoid. The transgenic rice was rich in pro-vitamin A. Since the seeds of transgenic rice are yellow in colour due to pro-vitamin A, the rice is commonly known as **golden rice**.

**c. Quality of seed protein :** Seeds are undergoing field trials of golden rice. Seeds are the reservoir of all proteins, amino acids, oils, etc. and used as food throughout the world. However, nutritional quality of legumes and cereals can be affected due to deficiency of certain essential amino acids such as lysine (in cereals like rice, wheat), methionine and tryptophan (in pulses e.g. pea). Following recombinant DNA technology improvement in quality of seed protein has been done. The two approaches were done for improvement in nutritional quality of seeds. In the first strategy a gene (encoding protein containing sulphur-rich amino acid) tagged with seed-specific promoter was transferred into cultured tissue of pea plant (rich in lysine but deficient in methionine and system). The transgenic pea produced protein containing sulphur rich amino acids. In the second strategy, improvement in endogenous genes is done. The modified gene introduced in cereals produces higher amount of essential amino acids such as lysine.

In 1999, the Indian scientists at ICGEB, New Delhi have successfully produced transgenic maize, tobacco, rice, etc. capable of producing interferon gamma (INF- $\gamma$ ).

**d. Edible vaccines:** The plants are capable of vaccines in large quantities at low cost but the purification may require more cost. Therefore, attention has been paid to produce such antigens that stimulate mucosal immune system to produce secretory IgA (S-1-A) at mucosal surface such as gut and respiratory epithelia because of their effectiveness on sites as most of the pathogens invade these regions. For example, bacteria and viruses are transmitted via contaminated food or water and cause diseases such as diarrhoea, whooping cough, etc. In 1990, the first report of the production of edible vaccine (a surface protein from *Streptococcus*) in tobacco at 0.02 per cent of total leaf protein level was published in the form of a patent application under the International Patent Cooperation Treaty. Thereafter, expression of a number of antigens in plants was successfully made and reported.

### Biodegradable Plastics

Polyhydroxybutyrate, (PHB) is a plastic-like natural polymer produced in many bacteria. It is seen on the inner surface of the bacterial cell wall. In advanced countries, it is used as renewable resource in the manufacture of biodegradable plastics. Biosynthesis of PHB is carried out by three enzymes namely *3-ketothiolase*, *Acetyl Co-A reductase* and *PHB synthase*. Ketothiolase is present in all plants.

A gene for acetyl Co-A reductase was isolated from the bacterium *Alcaligenes eutrophus* and introduced into *Arabidopsis thaliana*. The transgenic *A.thaliana* strain (strain A) produced acetyl Co-A reductase. Similarly, PHB synthase gene was isolated from the same bacterium and introduced into *A.thaliana*. The transgenic plant (strain B) produced the enzyme PHB synthase in the cells.

### Stress Tolerant Plants

Difficulty for the plants to survive is called stress. It is caused by extreme cold, heat and drought. Plants that tolerate the stress are called **stress tolerant plants**. Stress tolerance is important for occurrence of a species in a wide range of climates.

### Cold Tolerant Plants

***Arabidopsis is*** a small green plant. It contains acyl glycerol phosphate (AGP) which makes the plant resistant to prolonged chilling. AGP is made from glycerol diphosphate by the enzyme **glycerol phosphate acyl transferase** (GPAT).

The GPAT gene of *Arabidopsis is* linked with CaMV 35S promoter and transferred to tobacco through Ti plasmid. The transgenic tobacco accumulates AGP in the cells and resists chilling as low as 10°C for a long time. They can be grown in cold areas too.

### Drought Tolerant Plants

Drought resistance in plants is mainly due to the presence of high level of polyols like mannitol and sorbitol. Polyols are derivatives of sugars.

### Golden rice

The golden rice developed by a Swiss consortium is another example of transgenic recombinant DNA (Fig. 24). This rice has genes to increase iron content, sulfur content, and carotene, as well as the enzyme phytase, which destroys the plant phytates that chelate iron. The goal of this project was to make a more nutrient rich rice, and targeted two nutrients, iron, and beta-carotene (a vitamin A precursor) that are lacking in diets of those who rely on rice as the diet staple in much of the world. Vitamin A deficiency is a leading cause of blindness in children in "third world nations", and is not reversible. It is estimated that 40 million children suffer vitamin A deficiency. Iron deficiency affects almost a quarter of the world's female population. Distribution of this rice was initially withheld from the market for a number of political reasons (none of which in this case were monetary). Golden rice is still controversial.

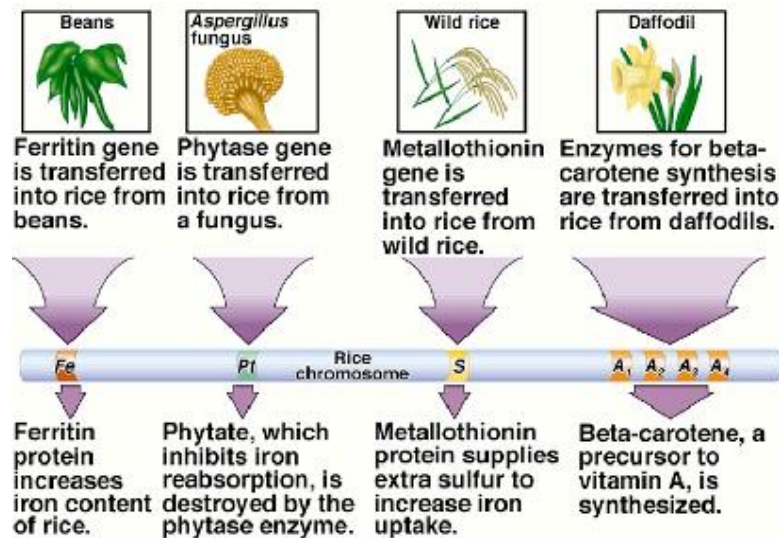

Fig. 24. Development of transgenic paddy and golden rice.

Genes for the fluorescent enzyme *luciferase*, isolated from naturally fluorescent organisms have been spliced into a several species as a "reporter" gene for a variety of genetic and research purposes, including, detection of hazardous materials in the terrain.

#### 4.4. DEVELOPMENT OF TRANSGENIC ANIMALS

Thus the transgenic animals can be used as *bioreactors* for large scale Pharmaceuticals production of valuable recombinant chemicals such as hormones, interferons, proteins, etc. Thus, manufacturing of recombinant drugs through transgenic animals is called 'Molecular farming' or 'molecular pharming'.

##### Strategies for Gene Transfer

Desired foreign genes are transferred into animal cells/embryos via virus. Microinjection targeted gene transfer methods, etc. as discussed below:

**a. Transfection of Animal cells/embryos:** During 1970s, attempts were made to produce transgenic animals. The first success was achieved in 1976 when mouse embryos were infected by retrovirus. The *retroviruses* are supposed to be an efficient vector that transfect the animal cells and deliver its genes

leading to production of transgenic cells/animals. The other viruses used for this purpose are Vaccinia virus, adenoassociated virus, herpes virus and bovine papiloma virus.

The transfected cultured mammalian cells have been used for diagnostics of oncogene (cancerous gene) as well as for gene therapy. The steps for detection of cancer gene follows: (i) isolation of DNA from tumour cell line. (ii) DNA fragmentation into 30-50 kb lon- pieces through mechanical shearing. (iii) dissolution in phosphate buffer followed by precipitation by adding CaCl. (h) pouring of this solution onto a laser of mouse 3T3 , cells: foci of cells developed, and (0 use of transfected cells in detection of cancer causing genes.

The other application of transfected cells is in gene therapy. Genes of desired function are inserted in cultured cells. The latter is placed in patient's body to rectify the malfunctioning.

**b. Transfer through Microinjection:** Microinjection method has also been developed and variously used in production of transgenic animals. So far gene transfer has been successfully carried out in several classes of animals viz., fish, birds, insects, mammals, etc.

**c. Gene targeting:** The other approach is the targeted gene transfer that involves transfer of genes at homologous sites in the host genome. It is done just to replace the wild type of mutant genes. For the first time it was done in bacteria and yeast. In 1985 success has been achieved it human also where human  $\beta$ -globin gene was transferred into recipient cell through recombination.

Targeted gene transfer is possible because the homologous DNA sequences are present at the targeted site as well as in vector that carries the desired gene of foreign origin. Besides, marker genes are also used to select the cells in which gene has been transferred at targeted site. It is achieved by: (i) using marker genes for antibiotic resistance.(ii) hypoxanthine phosphoribosyl transferase (HPRT) and (iii) polymerase chain reaction.

Gene targeting is also done by using embryonic stem (ES) cells as described earlier. The ES cells are allowed to aet transfected by vector containing desirable genes. In transfected cells targeting of gene to specific site by homologous recombination occur. Thereafter, the transfected cells are identified and isolated from bulk. They are multiplied and introduced into blastocyst through microinjection. The blastocyst is transferred into uterus of a surrogate mother for further developmental stages. The animals. which are born. are checked for the presence of transgene. The transgenic animal is crossed with a normal one to study the inheritance of introduced foreign gene. An outline of production of transgenic mice is shown in Fig. 25

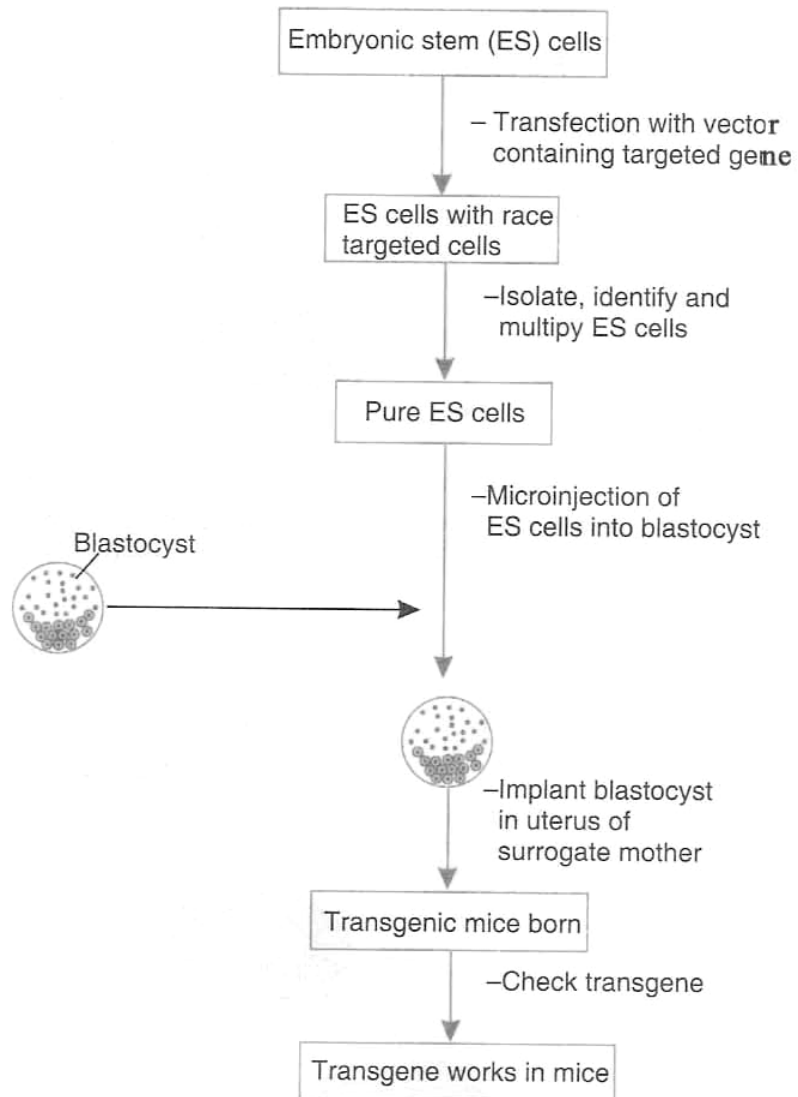

Fig. 25. Diagrammatic production of transgenic mice targeted gene transfer through ES cell.

**d. Knockout mice:** Transgenic mice that carry a knockout gene (*i.e.* gene of interest replaced by a non-functional gene) is called **knockout mice**. Now it is possible to select and knockout (remove a gene and make genetic modifications in the ES cells and mouse. Different types of model mouse can be developed to understand the function of various genes *e.g.* disease development. For example, knockout mice have helped the immunologists to understand the effect of knockout gene on immune system in animals. Various knockout mice are being used in immunological research. Production of knockout mice (gene targeted) is accomplished in the following steps.

1. Isolation and culture of ES cells from inner cell mass of a mouse embryo.
2. Induction of a mutant or disrupted gene into the cultured ES cells and selection of homologous recombinant cells in which genes of interest have been knocked out. Transgene works in mice.
3. Injection of homologous recombinant ES cells into a recipient mouse embryo and transfer of manipulated embryo into uterus of surrogate mother mice.
4. Mating of chimeric offspring heterologous for disrupted (gene to produce homozygous knockout mice).

### 1. Transgenic Mammals

For the first time in 1982, there appeared a report on the transfer of human growth hormone gene rat fused to the promoter of mouse metallothioneine I gene (Palmiter *et al.*, 1982, 1983). It was done by microinjection method. Because of presence of a novel gene, there has been a drastic increase in body weight of mice (for detail method see Chapter 7). Since then a large number of transgenic mammals and other animals have been produced such as cow pig, rabbit, goats, sheep, fish, etc. The purpose of production of transgenic animals has been to produce more protein in milk and meat, disease resistance, leaner meat, good quality wool and more specifically improvement in genetic traits. They are also used as bioreactor for molecular farming.

### 2. Transgenic sheep

So far it is not clear why the rate of transgenesis in sheep is very low *i.e.*, 0.1 to 0.2 per cent. It needs improvement by regular check through the biotechnological methods (using PCR, etc). Method of production of transgenic sheep is the same as described for transgenic mice (Fig. 11.8). Due to commercial appeal, the Pharmaceutical Proteins Ltd. Cambridge (UK, provided fund to J.P. Simons for the production of transgenic sheep. In 1988, Simons reported first production of transgenic sheep. He first produced two transgenic ewe that consisted of about 1G copies of human antihaemophilic factor IX gene in the form of cDNA. It was fused with about 10.5 kb long  $\beta$ -lactoglobulin ( $\beta$  LG) gene. Moreover, the  $\beta$  LG gene is important for the expression of gene in mammary gland. The ewes secreted human alpha-1 antitrypsin ( $\alpha$ -1 AT) *i.e.* human factor IX in milk because the gene had tissue specific expression. In spite of low expression of transgene the  $\alpha$ -1 AT is active. The transgenic sheeps were born in summer 1986. Again they were mated at the end of the year 1986. Single lamb was born from each ewe in 1987 that inherited  $\beta$  LG-factor IX transgene. Due to the presence of both the genes factor IX was secreted in milk.

In 1991, Alan Colman and coworkers at Edinburgh produced five transgenic sheep, four female and one male. The transgene was ovine- $\beta$ -lactoglobulin promoter fused to  $\alpha$ -1 AT gene, The concentration of  $\alpha$ -1 AT in milk was recorded to about 35 grams per litre. The biological activity of protein derived from milk was the same as that of plasma derived antitrypsin.

A.J. Clarke (Edinburgh, Britain) produced transgenic sheep that secreted either of two human proteins (the blood clotting factor IX or elastase and inhibitor  $\alpha$ -1 antitrypsin) in their milk. Both the proteins have important medical applications. Clark and co-workers inserted the coding sequence for these proteins into the  $\beta$ -lactoglobulin gene of the sheep and microinjected the chimeric constructs into the fertilised eggs. These eggs were implanted into the surrogate mother to produce the transgenic lamb. The transgenic sheep exhibited no apparent side effects from the production of both human proteins in their milk.

### 3. Transgenic Fish

For fishes, genetic engineering aims at increasing growth rates and feed utilization, increasing their tolerance to unfavourable or stressed environments, resistance to diseases, controlling reproduction and improving food quality characteristics.

Application of the following techniques can give rise to genetically engineered organisms: (1) cloning of genes and transfer with the aid of vectors; (2) direct injection of genetic material; and (3) fusion of two or more cells by un-natural techniques .

In many cases, transgenic fish have been produced through the microinjection of foreign DNA into fish eggs soon after their fertilization. The injection is done shortly after fertilization, usually at the 1-4 celled stage. Since fish eggs commonly have a tough outer membrane (chorion), an opening has to be made by

microsurgery before the glass needle is inserted. Another approach is to insert the glass needle through the micropyle (Brem *et al.*, 1988), micropyle is the pore through which sperm enters the egg during fertilization. The introduced gene replicates at the time of development of embryo. In most of the fish fertilization is accomplished out side in water. Therefore, embryo of different developmental stages can be collected easily. **In those cases where microinjection technique is not successful, transgenes are incorporated into embryos through electroporation technique.** This technique does not significantly reduce survival. It effectively integrates the inserted DNA into the fish genome.

Several different species and genes have been used in these experiments, but there has been greater emphasis on the introduction of growth hormone genes into salmon so as to increase the growth. Inheritance of transgene occurs in the Mendalian way. Stuart *et al.* ( 1988) found that spermatozoa transgenic trout and zebrafish containing oreign DNA transmitted the transgene to the next generation. Normal oocyte fertilized with sperms of transgene fish gave rise to offsprings of which 50 per cent of F1 offsprings contained foreign genes. The number of transgenic fish increased F2 generation. This method has successfully yielded transgenic individuals in several fish species, e.g. rainbow trout, Atlantic salmon, common carp (*Cyprinus carpio*), tilapia (*Oreochromis niloticus*), and northern pike.

Fish are the important source of fat and proteins for humans and the delicious diets are prepared in certain societies. Therefore, demand of good quality fish is increasing gradually. Gene transfer in embryos of several species of fish such as medaka fish, salmon, carp, zebra fish, goldfish, trout and cuttlefish has been successfully achieved.

## 4.5. BASIC PRINCIPLES AND APPLICATIONS

### A. Basic Principles of Transgenic Plants

**1 Insect-resistant plants:** Insects are harmful to crop productivity. Extensive use Of Chemical insecticides are hazardous, Plant genetic engineering approach for insect resistance is specific. The insecticidal toxin gene is introduced into the plants and the expression of cloned gene produces a toxin, which is lethal to insects. The classical example is Transgenic Bt cotton, in which an insecticidal Bt toxin gene from *Bacillus thuringiensis* have been successfully cloned. Efficient expression of Bt crystal protein can control insects by paralyzing its midgut.

**2 Virus-resistant plants:** Viruses can cause substantial crop loss. The use of chemical spray cannot control completely. The meristem culture has been tried for controlling few viruses.

Genetic engineering strategies for virus resistant plants have effectively controlled several viruses. The cloning of Tobacco Mosaic Virus (TMV) coat protein gene in transgenic tobacco plant showed high level of resistance to TMV infection. In RNA mediated protection only infected plant cells are killed by degrading all RNA molecules by specific expression of ribonucleases cytotoxic enzyme.

**3 In post-harvest technology:** Senescence in fruits and flowers induce ageing process. Softening and ripening are the two physiological changes associated with spoilage in fruits and vegetables. By using antisense RNA technology, ripening and softening process can be delayed by blocking the synthesis of ripening related enzyme (Ace synthase and a polygalacturonase). The calgene company marketed transgenic tomatoes with the trade name "flavrsvr".

**4 Pharma Plants:** Pharma plants are Transgenic plants tailored to synthesise antibodies and vaccines. If plants are successful as green factories of edible vaccines, then the vaccination problem of Third World countries can be solved. **Edible vaccines** do not require special form of transportation, refrigeration or needles for administration. Edible vaccines may be used to protect against the diarrhea causing pathogen E. coli. Upon consumption of transformed potatoes containing E. coli protein coding gene, the E coli proteins formed in the human body then induce tile production of antibodies against the proteins, conferring resistance. Apart from vaccines, plants can also be made to produce an edible form of the hormone insulin. Feeding transgenic potatoes containing the hybrid human insulin genes and cholera toxin subunit gene to mice delayed the onset of symptoms by few weeks.

Mass production of expensive monoclonal antibodies in plants is also possible. These antibodies can be used to treat various diseases. Antibodies made in soya plants prevent infection of mice by herpes virus and antibodies made in tobacco helps to prevent the bacterial infections. Antibodies produced from plants are purer, safer and less expensive compared to those made from animals.

**5 Biopolymer Productions:** As plastics are currently synthesized fro non-renewable sources such as petroleum products, researchers are constantly in search of alternative methods. One particular approach involving the insertion of three poly-3-hydroxybutyrate (PHB) - related genes into *Arabidopsis* has not been

successful due to its brittle nature. In order to overcome this problem four different genes have been transferred into *Arubidopsis* to produce a copolymer of PHB and poly-3 hydroxy butyrate valerate (PHBV).

## B. Basic Principles And Application Of Transgenic Animals

### Application of molecular genetics to improve milk production

The application of molecular genetics can potentially help improve not only **milk** production by elite dairy cattle but also such parameters as the **cheese-making quality** of the milk, and a change of the protein vs fat ratio of the milk. Important candidate genes for milk performance are known. The four casein encoding genes have been allocated to a short segment of bovine chromosome 6. Two whey protein-encoding genes  $\alpha$ -lactalbumin and  $\beta$ -lactoglobulin have been sequenced. Genetic variants relating to the coding regions of these genes have been described and attempts have been made to correlate such gene variants with parameters of milk performance.

### Animal health traits

Increasing attention is also being paid to animal health traits. Hereditary defects are genetically determined deviations from the norm in body build or body function. These defects reduce viability and performance. They impair animal health and reduce profitability for the livestock owners. **Hereditary diseases** cannot be treated by therapy. Their incidence can be reduced by suitable breeding programmes. **Genetic defects** have therefore to be systematically recorded and economically evaluated in the herds of breeding and working animals.

The following are some hereditary diseases receiving attention by animal breeders: 1. Bovine leucocyte adhesion deficiency (BLAD): caused by a point mutation in the CD.18 gene, which leads to an impairment of the immune defence system (simple autosomal recessive gene).

### Bacterial genes for wool production

Work is underway on introducing bacterial genes which control cysteine production into sheep. In sheep, the rate limiting step in the production of wool is the availability of cysteine. The animals cannot be given the **amino acid in the form of a food supplement** because most of the cysteine is broken down by bacteria in the rumen to produce hydrogen sulphide. In order that sheep could synthesize their own cysteine, only two bacterial genes would need to be introduced. the genes for serine transacetylase and -acetylserine sulphhydrylase. These genes can be isolated from bacteria and brought under the control of a metallothionein promoter. When introduced into cell cultures, cells carrying the construct could be induced to express the enzymes and thus synthesize cysteine. in the presence of zinc. Transgenic sheep have been produced which carry the bacterial genes and testing of cysteine production is being planned. Such transgenic sheep could produce twice as much wool as a non-transgenic sheep.

### Application of transgenic technology in the expression of insecticidal proteins

Another application of transgenic technology in **sheep** is the expression of **insecticidal proteins** in the wool to avoid the need for chemical spraying and to reduce the number of animals suffering because of fly strike. Chitinase genes found in plants may be introduced into sheep. If sheep could be induced to secrete chitinase in the skin, insect larvae would be killed by ingesting the protein and die before causing damage to the sheep. This endogenous insecticide would eliminate the need for chemical insecticides which can build up in the environment and lead to problems of insect resistance. The chitinase gene may be expected to pose no risk when introduced into sheep because it is known to be non-toxic to mammals, and it would not change the dynamics of the blow fly population-, also insects would be unlikely to evolve resistance to the protein. If fly strike was reduced, substantial benefits might be gained in animal welfare and animal health.

### New vaccines through Recombinant DNA technology

Recombinant DNA technology can help in the development of new vaccines. One of the simplest techniques is the isolation and characterization of antigens to enable a very pure vaccine to be produced. This approach has been adopted in developing a vaccine against the cattle tick, *Boophilus tniieroplus*. Alternatively, non-pathogenic viruses are used as carriers for foreign proteins from pathogenic ones, By adding rinderpest genes to the cowpox virus genome, a rinder pest vaccine has been produced which has a long shelf-life and is less susceptible to heat damage than the existing vaccine. Non-infectious particles, such as the shell of the foot and mouth disease virus, can also be produced by recombinant DNA techniques.

**The production of transgenic animals with increased disease resistance** is likely to take much longer than the development of improved vaccines. Firstly, genes associated with disease resistance have to be identified. Once located, these genes would take a long time to introduce into the breeding stocks. Conventional breeding techniques have concentrated on increased productivity rather than disease

resistance. Preliminary work on gene mapping with the fowl has suggested that some disease resistance is coded by single genes and thus may be manipulated by conventional breeding or inserted as transgenes. However, other disease resistance traits are likely to be complex multilocus characteristics which might not be amenable to gene transfer techniques.

**Reproductive technologies** exert a strong impact on animal breeding. Improvements in animal productivity have been achieved because of breeding strategies incorporating artificial insemination (AI). The ability to preserve valuable cattle semen for distribution to different herds and to different countries has revolutionized animal breeding programmes. In developing countries, the importation of semen from genetically superior bulls has enabled a doubling of milk production in some herds. Importing frozen semen also does not have the problems of disease monitoring and acclimatization associated with the importation of live animals to such countries. Where indigenous breeds are being replaced by animals bred from imported semen, the cryopreservation of semen can also help to preserve a valuable gene pool.

### **Embryo transfer techniques- resistance to indigenous diseases**

Embryo transfer techniques have the advantage that the whole animal genome is available rather than just half as in all. With the development of non-surgical techniques for the collection and re-introduction of embryos from cattle, embryo transfer may not have a significant impact on animal welfare. In fact, by transporting frozen embryos between farms and countries animal welfare may improve. Transferring embryos between countries also enables the resulting calves to acquire resistance to indigenous diseases via the colostrum thus avoiding the disease problems which are encountered when importing young animals.

### **Productions proteins in the milk of transgenic animals**

Some proteins cannot be produced by bacterial fermentation because of the need for the protein to be glycosylated to be biologically active. Producing such proteins in the milk of transgenic animals is cheaper than in bioreactors, and sufficient quantities to treat all patients could be harvested. Quite high concentrations of valuable protein (up to 30 g/litre) may be expressed in transgenic sheep. This would give a yield of 1.5 kg of human protein per sheep per lactation: this protein is in great demand as it is useful for treating patients suffering from emphysema, a serious disease of lungs. These patients need 4 g of protein per week. The protein expressed in milk would cost at least 10 times less to purify than the same protein produced in a conventional bioreactor. In order for the protein to be marketed without further clinical and animal testing, the recombinant protein has to be demonstrated to be identical to the existing product extracted from human blood. So far, the amino acid sequences of the sheep-derived human protein and its bioactivity have been found to be identical to the human-derived protein. In U.K., scrapie-free sheep have been imported from New Zealand for the transgenic work. The large amounts of protein produced by transgenic animals might also enable oral delivery of therapeutic proteins. Protein drugs administered orally need to be given in large doses to compensate for the protein of the dose lost through digestion.

### **Identification of carcinogens**

Expanding use of custom-made transgenic animals and cell lines could well reduce the number of animals used in laboratories a good example is that of transgenic mice which have been designed to help in the identification of carcinogens. These developments may reduce the number of animals used in toxicity testing many fold.

### **Artificial organs**

Immortalized cell lines could also be produced from transgenic animals to facilitate in *vitro* testing of new products. Reconstructed tissues have also been designed which mimic kidney and skin. Experiments can now be conducted using these artificial organs rather than using real animals.

### **Human haemoglobin production from transgenic pigs**

The gene construct used to create the transgenic pigs contained the human betaglobin, locus control region (LCR). A total of 709 ova were injected with the construct. These ova were then transferred into 19 females, 13 of which retained the ova. 112 piglets were born out of which 3 transgenic animals could be identified.

Analysis of DNA from the transgenic pigs revealed that the 3 pigs carried approximately 10.2 and 1 copies of the haemoglobin gene complex per haploid genome respectively. Transgenic pigs expressed a product which migrated to the same position as human haemoglobin.

The human haemoglobin was purified from pig blood haemolysate by separation on an anion exchange column. Elution yielded 3 samples, one of which was essentially pure human haemoglobin free from pig or hybrid haemoglobin contaminants. Following separation, the human haemoglobin was found to be > 99% pure.

Transgenic pigs expressing human haemoglobin can potentially be a valuable source of haemoglobin for a red blood cell substitute. Since a simple separation technique is available, and the properties of the pig derived haemoglobin are similar to normal haemoglobin, large scale production would be possible if sufficient transgenic animals become available.

### Gene therapy techniques

Transgenic animals carry a potential as models for human disease. Sickle cell mouse is a particularly useful model as it has enabled the testing of **new antisickling agents** and has helped research into what precipitates a sickling crisis.

The development of gene therapy techniques has also become possible by the use of transgenic mice. Researchers have cured shivering mice by the insertion of a myelin basic protein gene and attempts **to transfer a normal globin gene into thalassaemic mice are underway**. The use of targeted mutagenesis to produce so-called '**knock-out**' mutations has enabled an animal model for cystic fibrosis to be produced. Such **animal models have aided the study of disease and the development of new therapies**.

The **embryo transfer technique** involves several steps starting with the stimulation of multiple egg production at ovulation in cattle or other mammals. Artificial insemination is followed by embryo recovery and as many as 15 embryos may sometime be recovered from one cow in this way. These embryos may either be preserved by freezing or immediately planted in a **surrogate mother cow**. The major use of the above technology is to **greatly increase the reproductive rate of valuable** but slow reproductive rate cows.

The production of identical calf twins by separating zygotic cells **and transplanting** them into surrogate cows has already been demonstrated in several countries. The use of natural and synthetic **animal hormones to stimulate growth** is being tried with interest in the production of **cloned animal growth hormones as feed additives**. This approach can lead to a more direct and **quicker method of producing bigger livestock** than generations of selective breeding.

**Control of genome activity:** This relates to the capability to insert recombinant DNA switches into the genome of a domestic animal with a view to regulating the timing of certain developmental functions such as mating capacity in cattle.

**The embryo transfer technique involves several steps** starting with the stimulation of multiple egg production at ovulation in cattle or other mammals. Artificial insemination is followed by embryo recovery and as many as 15 embryos may sometime be recovered from one cow in this way. These embryos may either be preserved by freezing or immediately planted in a surrogate mother cow. The major use of the above technology is to greatly increase the reproductive rate of valuable but slow reproductive rate cows.

**Superovulation** can be induced by gonadotrophins or by equine pituitary extract. As many as 50 calves may be produced by single cow in one year, as against only 1 produced normally. In addition, as frozen embryos from some superior strains may be sent from one country to another, it becomes possible for a developing country to import such superior embryos and then grow them to maturity in local surrogate mother animals. This can help rapidly upgrade its cow wealth.

**The production of identical calf twins** by separating zygotic cells and **transplanting** them into surrogate cows has already been demonstrated in several countries. The use of natural and synthetic animal hormones to stimulate growth is being tried with interest in the production of cloned animal growth hormones as feed additives. This approach can lead to a more direct and quicker method of producing bigger livestock than generations of selective breeding,

### Transgenic fish

Transgenic technology in fish is concerned with studying growth hormones. In fishes, transgenes can be introduced into fertilised egg and further development of embryo takes place in temperature controlled environment. Further, fertilisation in fishes is external and hence implantation into the female is not required as in case of mammalian system. Some fishes like winter flounder exhibit unique tolerance to freezing temperature due to its antifreeze gene. The antifreeze protein protects fishes from freezing under extreme cold conditions in the sea, In one Study, antifreeze gene was isolated and Successfully cloned in salmon fishes for freeze tolerance, and gene for disease resistance will be introduced into temperate and tropical fishes.

#### 4.6. THE HUMAN GENOME PROJECT

The Human Genome Project (HGP) is an international research project aiming to improve understanding of the basis of human heredity (genomic structure of man). It is aiming at sequencing all DNAs of man and at determining the location of various genes in the DNAs. Many Government and private sectors have been taking part in the ongoing project. It focuses on the complete characterization of the human genome, all the human genetic material, including the estimated 50,000 to 100,000 genes contained in human DNA.

The genome project was initiated in 1988. It is under the international administration of the '**Human Genome Organization**' (HUGO). It is funded by the **Department of Energy** (DOE) and **National Institutes of Health** (NIH) in the USA, the **European Commission** (EC) and Britain's **Wellcome Trust**. Many publics have also been donating for this scientific investigation.

The research works in the project have been conducted in research laboratories in six nations. The most important among them are the **National Human Genome Research Institute (USA)**, **Sanger Centre** (England) and **Celera Genomics**. 12,000 base pairs of human DNA have been sequenced in every minute. It is expected that the project will be completed in the year 2005.

The HGP is one of several genome projects designed to describe the genomes of bacteria, yeast, crop plants, farm animals, and organisms used in medical research. One central aim of all these projects is to promote the understanding of the basic biochemical processes of living organisms. It is hoped that outcomes of the HGP will be to make possible early detection of human diseases, effective preventative medicine, efficient drug development, and personalized therapies.

##### Importance of Human Genome Project

Most inherited diseases are rare, but taken together, the more than 3,000 disorders known to result from single altered genes rob millions of healthy and productive lives. Today, little can be done to treat, let alone cure, most of these diseases. But having a gene in hand allows scientists to study its structure and characterize the molecular alterations, or mutations, that result in disease. Progress in understanding the causes of cancer, for example, has taken a leap forward by the recent discovery of cancer genes. The goal of the Human Genome Project is to provide scientists with powerful new tools to help them clear the research hurdles that now keep them from understanding the molecular essence of other tragic and devastating illnesses, such as schizophrenia, alcoholism, Alzheimer's disease, and manic depression.

Gene mutations probably play a role in many of today's most common diseases, such as heart disease, diabetes, immune system disorders, and birth defects. These diseases are believed to result from complex interactions between genes and environmental factors. When genes for diseases have been identified, scientists can study how specific environmental factors, such as food, drugs, or pollutants interact with those genes.

Once a gene is located on a chromosome and its DNA sequence worked out, scientists can then determine which protein the gene is responsible for making and find out what it does in the body. This is the first step in understanding the mechanism of a genetic disease and eventually conquering it. One day, it may be possible to treat genetic diseases by correcting errors in the gene itself, replacing its abnormal protein with a normal one, or by switching the faulty gene off.

Finally, Human Genome Project research will help solve one of the greatest mysteries of life: How does one fertilized egg "know" to give rise to so many different specialized cells, such as those making up muscles, brain, heart, eyes, skin, blood, and so on? For a human being or any organism to develop normally, a specific gene or sets of genes must be switched on in the right place in the body at exactly the right moment in development. Information generated by the Human Genome Project will shed light on how this intimate dance of gene activity is choreographed into the wide variety of organs and tissues that make up a human being.

##### Techniques of the HGP

The HGP, which is expected to last for 15 years, has two major components: first, the creation of maps of the 23 pairs of human chromosomes and secondly, the sequencing of the DNA making up these chromosomes. Geneticists use two types of maps to characterize the human genome: genetic linkage maps and physical maps (Fig.4). The maps depict the relative positions of DNA markers; both known genes and DNA sequences with no known coding function.

## Genetic Linkage Maps

At the lowest resolution genetic linkage maps depict relative chromosomal locations of DNA markers and are created by following the pattern in which they are passed through family pedigrees in relation to other known markers

## Physical Maps

Physical maps describe the characteristics of the chromosomal DNA molecule and can be at several levels of resolution. At the lowest resolution is the cytogenetic map, showing the chromosomal banding visible in stained chromosomes (Fig. 26). Higher level physical maps are achieved by dividing the chromosomal DNA into shorter fragments (which may include the markers of the genetic linkage map) with restriction enzymes. The fragments are then duplicated and characterised. The correct location and order of the fragments on the chromosome is then deduced using overlapping common sequences as guides.

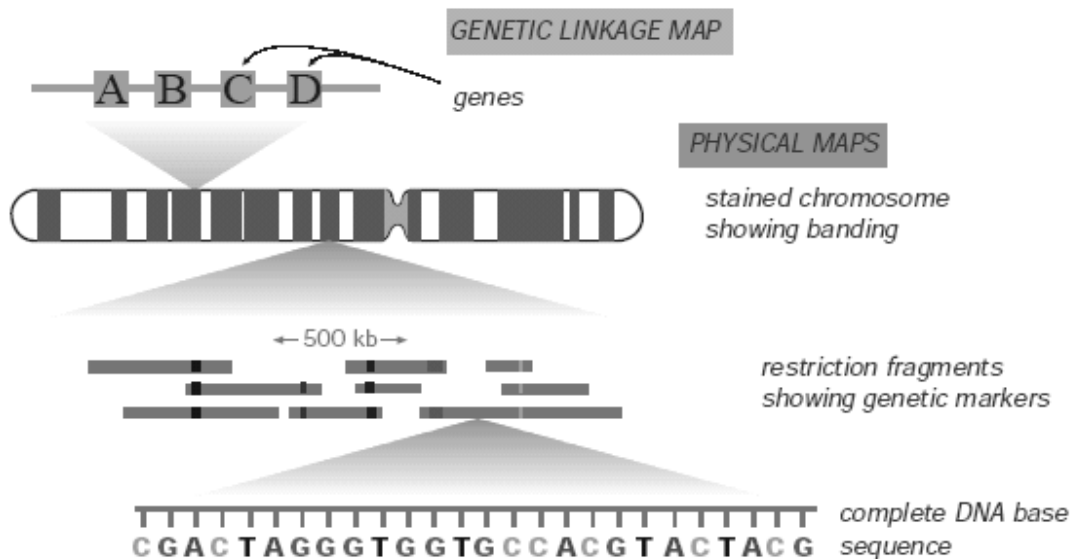

Fig. 26. Mapping a chromosome

## Sequencing

Ultimately the characterization involves determining the complete base sequence of the fragments (the highest resolution physical map). One of the most frequently used sequencing methods is that of Sanger. An important technique used to propagate DNA fragments in the mapping and sequencing activities of the HGP is the polymerase chain reaction (PCR). A detailed description of this can be found in EIBE Unit 2 DNA-profiling

## The Human Genome Project

The eminent British molecular biologist Sydney Brenner brought a hearty laugh from his audience by suggesting that some future graduate student might define a mouse as 'ATC, GCC, AAG, GGT, GTA, and ATA ....' Every year, however, the idea of defining an organism by the sequence of its DNA bases seems a little less far fetched. This is also true for Man because in the middle of the 1980s a huge project, named the Human Genome Project (HGP) was begun with the aim of deciphering the complete human DNA.

When, about forty years ago, it was proved that the DNA molecule is responsible for heredity, it brought together two groups of researchers; some were interested in the determination of the loci and the function of genes, while others wanted to know the structure of those molecules that include the information for control of biochemical processes. As a result of this great interest, during the following years more and more improved techniques for the isolation, multiplication, manipulation and analysis of DNA fragments were developed. A key outcome was the so-called recombinant DNA technology which revolutionized medical/biological research. It made possible the identification of genes for several hereditary diseases (Fig. 27).

The knowledge gained by this technique showed that research on the decoding of the whole human genome and the locating of all genes could be taken a long way further. The achievement of this became the declared aim of the HGP.

The two sets of 23 chromosomes in human cells contain about 50 000 to 100 000 genes that make up probably not more than 5% of the whole DNA. The first aim of the HGP is to determine the location of all

genes on the 23 chromosome pairs, *i.e.* on the 44 autosomes and the 2 sex chromosomes. This is followed by determination of the base sequence, very important information for the identification of the particular gene function. Finding the localisation of the genes is known as **mapping**; **the determination of the base sequence is sequencing**. **The final aim of the HGP is the sequencing of the whole human DNA including the non-coding parts.**

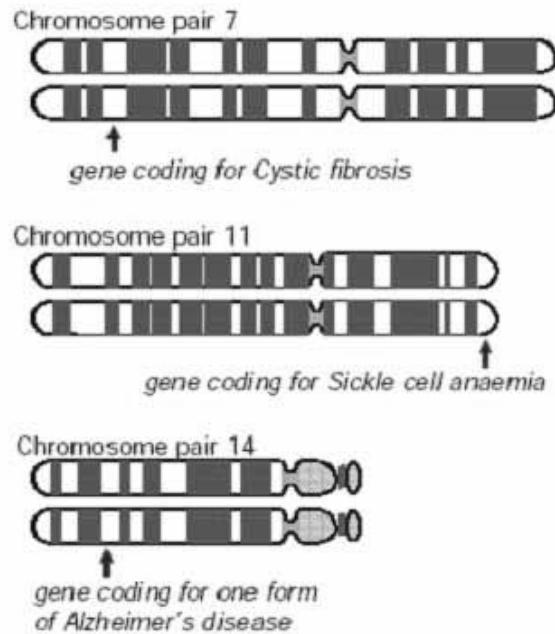

Fig. 27. Three human chromosomes with known loci for hereditary diseases.

The information from these investigations will lead to new knowledge about human diseases and to new ways of diagnosis and treatment of disease. In addition, the findings will give information about the origin of the various population groups and the evolution of Man. The dimensions of the project are difficult to imagine. For example, if you magnify the size of a human cell to the circumference

### Adopted Methodology

A somatic cell of human being contains 23 pairs of chromosomes. Each chromosome is composed of a long double-stranded DNA and histone protein. It is estimated that there are 3.2 million base pairs in the DNA of all these chromosomes. Among them, 2 million base pairs were already sequenced. The general methodology of the genome project is outlined below:

### Obtaining DNA

A cell culture containing a human cell line is homogenised in sucrose solution using a pestle. The homogenate so obtained is subjected to differential centrifugation chromosomal fraction. This fraction is added with a lysis buffer and again centrifuged using an ultracentrifuge to separate different chromosomes according to their sizes. Thus human chromosomes 1-23 are isolated and numbered properly.

In the chromosomes, DNA is wrapped around histone proteins in the form of small balls. These DNA wrapped units are called **nucleosomes**. Each chromosome, say for example chromosome 1, is suspended in a solution containing Tris-HCl, EDTA and NaCl and stored at -20°C. This treatment releases histones from the nucleosomes, releasing the DNA free. The DNA is isolated from it by Cesium chloride density gradient centrifugation. Each DNA is about 5 feet long.

### Preparation of DNA for Study

The long DNA of a chromosome is cut into small pieces of 5000 -10,000 nucleotides using a restriction enzyme that cuts the DNA at long distances. The individual pieces of DNA are separated by agarose gel electrophoresis on the basis of restriction fragment length polymorphism (RFLP). Each at every DNA fragment so obtained is placed in a vial and stored at 20°C for future use. One DNA fragment is inserted into a plasmid DNA to construct a rDNA. The rDNA is introduced into *E. coli* for *in vivo* amplification of that DNA fragment. Consequently, billions of copies of that DNA fragments are made. In this way, each and every DNA fragment is amplified.

## Sequencing and Analysis

The amplified rDNA is isolated from the bacterial cells and the target DNA is separated. It is cut with a restriction enzyme to **generate small DNA fragment**. Fluorescent dye visible under laser light is added to the terminal nucleotide of each DNA fragments. The resulting DNA solution is poured into 96 tubes inside the **DNA sequencing machine**. In the tubes, the DNA fragments are electrophored very fast and this can be observed by fluorescence *recorder* in the gene machine.

The bases in the overlapping segments are identified and assembled in a linear order by using computer database. In this way, all DNA fragments of a chromosome are sequenced to recreate its original nucleotide sequence. Such a study is conducted on all 23 chromosomes of human genome to understand the exact genome structure of man.

## Applications of Genome Project

1. Genome project provides database information of DNA sequences of man. Biotechnology based companies may use the information to manufacture human proteins which are of much use in the human disease treatments.
2. It helps to detect genetic disorders in man and their inheritance. So far 289 genetic diseases have been known (Table. 8).

Table 8. Gene sequence and diseases in man genome.

Chromosome and gene sequence	Human disorder
<b>Chromosome 1:</b>	
GBA gene	Gaucher disease
HPC I gene	Prostrate cancer
PS 2 (AD4)	Alzheimer's Disease
<b>Chromosome 2</b>	
CREB	Loss of memory
PAX3	Waardenberg syndrome (Mismatching in colours)
<b>Chromosome 6:</b>	
SCA I gene	Spinocerebellar atrophy (Loss of contraction)
IDDM I gene	Diabetes associated with kidney Failure
EPM 2 A	Epilepsy
<b>Chromosome 7</b>	
GCK gene	Diabetes
CFTR	Cystic fibrosis
OB gene	Obesity
<b>Chromosome 10</b>	
PAHX gene	Refsum disease
OAT gene	Jyrate atrophy (Progressive loss of vision)
<b>Chromosome 17</b>	
BRCA I	Breast cancer
<b>Chromosome 20</b>	
DA I	Severe combined Immunodeficiency
<b>Chromosome Y</b>	
SR-Y(TDF)	Testis differentiation factor

3. A proper remedial gene can be chosen and administered to treat genetic disease.
4. The action of harmful genes is blocked by introducing an antisense gene to stop the genetic disease.
5. The American company, **Incyte Genomic** has manufactured a gene chip with 10,000 gene kits. This chip can be used to detect genetic diseases, infectious diseases, oncogenes, parasitic worms etc. at once during clinical diagnosis. The diagnosis is very fast; it will be over within 3 hrs.
6. Genomic project will help to understand what the real bases of human life are? Walter Gilbert a professor of Harvard University- says 'What is to be a man will come to our knowledge when the Genome project is completed.
7. By matching the human genome with the genome of Drosophila. Scientists conclude that this fly has remedial genes for 177 genetic diseases in man. Therefore, the remedy is always around us.
8. The information about the genome will be utilized to design babies with many superior characters such as skill, strength and free of genetic disorders.

9. The HGP is one of several genome projects designed to describe the genomes of bacteria, yeast, crop plants, farm animals, and organisms used in medical research. One central aim of all these projects is to promote the understanding of the basic biochemical processes of living organisms. It is hoped that outcomes of the HGP will be to make possible early detection of human diseases, effective preventative medicine, efficient drug development, and personalized therapies.

### Short Questions

1. Micropropagation
2. Transgenic plants
3. Encapsulated seeds
4. Production of virus-free plants
5. Secondary metabolites
6. Transgenic plants
7. Nif gene
8. Herbicide resistant transgenic plants
9. Edible vaccines
10. Edible antibodies
11. Embryo transfer/ Embryo Transplantation
12. Superovulation
13. Gene Injection/ Microinjection
14. Electroporation technique
15. Transgenic animals
16. Transgenic fish
17. Transgenic sheep
18. Knock out mice
19. Human genome project

### Questions

1. Discuss in detail the applications of micropropagation in horticulture and forestry.
2. Explain the applications of DNA technology in agriculture.
3. Describe the applications of DNA technology in animal husbandry.
4. Write an essay on the biotechnological applications of plant cell and tissue culture in agriculture.
5. Give a detailed account of molecular farming from transgenic plants with emphasis on immunotherapeutic drugs.
6. What do you know about transgenic plants? Write in detail on selectable markers and their use in production of transgenic plants.
7. What do you know about transgenic animals? Write in detail on different methods used in production of transgenic animals.
8. Write an essay on different methods used in production of transgenic plants.
9. Discuss in brief the benefits of plant cell culture with regard to plant pathology.
10. Write an essay on in vitro selection of cell lines for disease resistance.
11. Give a detailed account of production of secondary metabolites for cell culture.
12. Describe basic principles and applications.
13. Write an essay on human genome project.

## 5. ANALYTICAL TECHNIQUES

### 5.1. Radioisotope techniques

#### 5.1. Application of radioisotopes in biological sciences

#### 5.1. Auto radiography

#### 5.1. Spectroscopic techniques

#### 5.1. General principles of Visible and Ultraviolet Spectrophotometry

### 5.1. RADIOISOTOPE TECHNIQUES

Radiation techniques are mainly concerned with radioactive material, radioactive decay, screening methods and quantification of radioisotopes. The principal aim of modern radiation biology is to study the effect of radiation on living systems and its applications to the benefit of mankind. **Radiation biology** has played a significant role in the progress of the biological field. **Radioisotopes** have been employed in the investigation of various cellular metabolic pathways such as protein synthesis, DNA replication, enzyme action etc. Besides, this technique is also being employed to study the effect of **radiation** on nucleic acid and its subsequent effect on the nature cellular functions. In medical field radio isotopic technique is widely employed in tumor therapy, immunotechnology and also as diagnostic tool in clinical biochemistry.

An **atom** consists of a positively charged nucleus with positively charged protons and neutral neutrons surrounded by electrons. In an atom, the number of electrons is always equal to the number of protons making the atoms electrically neutral. The number of electrons in an atom denotes its atomic number and the number of protons and neutrons together represents the mass number. Atoms, which have the same atomic number but different mass numbers, are called **isotopes**. A stable isotope is one in which the nucleus has equal number of protons and neutrons. If the proton-neutron ratio of atoms is more than one, **they become unstable**. They are called **radioisotopes**. The process of emission of electromagnetic radiation by the radioactive isotopes is called **radioactivity**, which may be natural or artificial (man-made). For example carbon contain four isotopes they are  $^{11}\text{C}$ ,  $^{12}\text{C}$ ,  $^{13}\text{C}$  and  $^{14}\text{C}$ . They exhibit different atomic weight due to differences in neutrons.  $^{11}\text{C}$  has five neutrons.  $^{14}\text{C}$  has eight neutrons. Similarly hydrogen (H) has three isotopes. They are  $^1\text{H}$ ,  $^2\text{H}$ , and  $^3\text{H}$ .

#### Types of Isotopes

The ratio of neutrons to protons in nucleus will decide on the stability of atom in nature. Isotopes are classified into two types one is stable isotopes and another is unstable isotopes (radioisotopes). The unstable radioisotopes can be converted into another element with the concomitant emission of radioisotopes. Some of the commonly used radio isotopes are  $^3\text{H}$ ,  $^{11}\text{C}$ ,  $^{14}\text{C}$ ,  $^{14}\text{Na}$ ,  $^{32}\text{P}$ ,  $^{35}\text{S}$  and  $^{59}\text{Co}$  of which certain radio isotopes such as  $^{14}\text{C}$ ,  $^{32}\text{P}$  and  $^{14}\text{C}$  are extensively used in biological system.

#### Radioactive Decay

Radioactivity is the emission of radiation by a radio isotopes. Radio isotopes emit three different types of radiation. They are alpha ( $\alpha$ ) rays, beta ( $\beta$ ) rays and gamma ( $\gamma$ ) rays. Following are emissions of some of the radio isotopes.

#### Nature of Radioactivity

Radiation arises from the decay of unstable isotopes (Fig. 28). These isotopes release subatomic particles and high energy photons. Subatomic particles include electrons, positrons and helium nuclei.

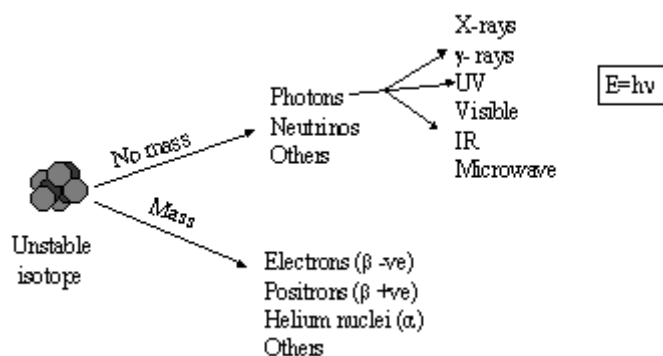

Fig. 28. Radiation derives from the release of sub-atomic particles.

You should note that energy based radiations are due to the release of photons. All photonic particles have the same "structure", but we classify them according to their energy quanta. That is gamma rays and visible light are both composed of photons. The difference is that the energy the photons in gamma rays is higher than that of visible light.

The energy (E) of a photon is determined by their wavelength ( $\lambda$ ). The energy of a photon can be calculated using Planck's constant (h):

$$E = \frac{hc}{\lambda}$$

where c is the speed of light

The energy of the photon increases with the frequency or the photon and decreases with the wavelength. For example, X-rays have a smaller wavelength than UV light and therefore have a higher energy quanta.

**$\alpha$ -rays:** Radio isotope of uranium element  $^{235}\text{U}$  emits  $\alpha$ -rays and converted in to thorium. Generally isotopes of element having high atomic numbers emits alpha particles. Emission of  $\alpha$ -particles result in a significant lightening of the nucleus due to reduction in the atomic number and decrease in mass number. The utility of  $\alpha$ -rays in biological system is insignificant and not frequently used. For example  $^{226}\text{Ra}$  decay by  $\alpha$ -emission to  $^{222}\text{Rn}$ . As the complex decay series begins which ultimately result in the formation of  $^{206}_{82}\text{Pb}$ .

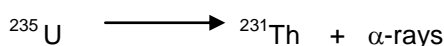
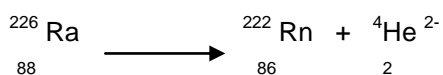

**$\beta$ -rays:** Radioisotope of carbon  $^{14}\text{C}$  emit  $\beta$  rays and undergoes conversion as follows:



The emitted  $\beta$  rays is negatron emission. In this type a proton by the ejection of a negative charged beta ( $\beta$ ) particle called a negatron ( $\beta\text{-ve}$ )

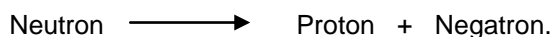

Negatron is high energy electron. As a result of emission the nucleus loses a neutron(electron) but gains a proton. Some isotope decay by committing emission of positively charged  $\beta$ -particles is referred as positron ( $\beta + \text{ve}$ ). When proton is converted into neutron positrons are emitted.



Positrons are unstable. As a result of positron emission, the nucleus loses a proton and gains a neutron.

### X-rays and $\gamma$ -rays

These are high energy photons. Gamma ( $\gamma$ ) emission involves electromagnetic radiation. They show shorter wave length than X-rays. In the production mode, these are produced in nuclear reactions. While X-rays are generated mainly because of bombardment of any heavy-element by high speed electron after atomic transition. Emission of  $\gamma$ -rays do not result in any change of atomic number or mass.

### The half life of Radioactive Isotopes

The most common method of describing how quickly an isotope decays is to use the half-life. The half life represents the time required for a 50% decrease in the radioactivity of an isotope. The longer the half life of an isotope, then the more stable it is. Unfortunately, to perform any serious radioactivity, the half life must be converted back to its specific decay rate equivalent using the following equation:

$$\lambda = \frac{\ln 2}{t_{1/2}}$$

$$t_{1/2} = \frac{\ln 2}{\lambda}$$

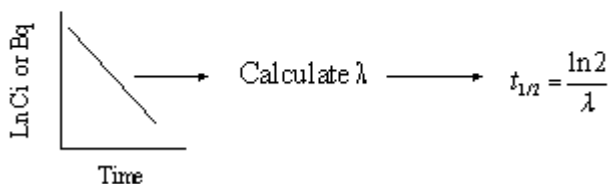

### Radioactive Units

Radioactivity is usually expressed in terms of Curies (Ci). Radioactivity is often expressed in terms of specific radioactivity. For example, the radioactivity of a sample may be 5.9 mCi per ml or mg of sample. One curie is equivalent to 37 billion disintegrations per second. One curie is equivalent to the decay rate of 1 g.

The Becquerel (Bq) is the SI unit for radioactivity. It is equal to the 1 disintegration per second (1 dps).

**One curie** is equal to 37 billion dps or 37 billion Bq

$$1 \text{ Bq} = 1 \text{ dps}$$

$$1 \text{ Ci} = 3.7 \times 10^{10} \text{ dps}$$

Although SI units are internationally accepted units, the Bq is currently not in common use, some regulating bodies will require that units be reported in Ci and in Bq.

The basic unit of radioactive decay is represented by curie (Ci). It can be defined as the amount of isotope that undergoes  $3.7 \times 10^{10}$  disintegration per second. Most commonly used decay units are millicurie (mCi) and microcurie ( $\mu\text{Ci}$ ).

Another unit is **Roentgen** (r), which is the quantity of radiation producing ions equivalent to one electrostatic unit of electricity through a volume of air. The effect of radioactivity in biological systems is expressed as Rad (Roentgen absorbed dose) and rem (Roentgen equivalent man). One rad is equal to 100 ergs per gram and one rem is approximately equal to 1.00 rad for  $\beta$ ,  $\gamma$  and X-rays and to 0.05 rad for  $\alpha$  rays.

### Natural Radioactivity

The spontaneous emission of highly penetrating radiations such as  $\alpha$ ,  $\beta$  and  $\gamma$  rays by the heavy elements like uranium, radium, thorium, etc. is called **natural radioactivity**. These elements are called **radioactive elements**. The  $\alpha$  particles are relatively larger in size, positively charged and are emitted by the nucleus. They contain two protons and two neutrons. They pass through straight lines with high velocity. They can ionize gases, affect photographic plates and produce fluorescence. The  $\beta$  rays are similar to electrons as they carry a negative charge. They are smaller than  $\alpha$  particles but their velocity is greater approaching that of light.  $\beta$  rays exhibit two types of spectra namely line spectra and continuous spectra. The line spectra are produced by the emission of electrons from the orbits of atoms whereas the continuous spectra are produced by the emission of electrons from the nucleus of atoms.  $\gamma$  rays are similar to X-rays and are nuclear in origin. They have very short wavelengths and are capable of emitting a large quantum of energy. The process of elimination of  $\alpha$ ,  $\beta$  and  $\gamma$  rays is called **particulate** or **corpuseular radiation** whereas the elimination of small units of energy namely photons or quanta are called **electromagnetic radiation**. Particulate particles travel at a speed less than that of light. On the other hand, photons travel at the speed of light.

### Artificial or Induced Radioactivity

The process by which the light elements are made into radioactive substances is called **artificial radioactivity**. These artificially induced substances also exhibit decay similar to natural radioactive elements but they emit electrons, neutrons, protons and UV rays. Almost all elements can be made into radioactive substances by bombarding them with particles like  $\gamma$  particles. The important artificial radioisotopes include tritium ( $\text{H}_3$ ), sodium ( $\text{Na}^{24}$ ), phosphorous ( $\text{P}^{32}$ ), cobalt ( $\text{Co}^{60}$ ), carbon ( $\text{C}^{14}$ ), iodine ( $\text{I}^{131}$ ), sulphur ( $\text{S}^{35}$ ), etc.

### Radioactive Disintegration

When an unstable atom emits radiation, either it changes the structure or energy level or both and this change is called **radioactive disintegration** or **radioactive decay**. The process by which the radioactive

substances disintegrate to form a series of new substances is called **successive disintegration**. After the decay, some parent substances exist so that the lifetime of radioisotopes is referred to as **half life**, which is the time taken for the disintegration of one half of the radioactive substances (rate of disintegration).

### Production of Radioisotopes

The isotopic forms of an element exist in nature. They can be extracted and purified from their natural sources. Due to several constraints isotopes are produced in nuclear reactors. Neutron (n) produced in nuclear reactors combine with an isotope of an element to produce a radio isotope. For example  $^{14}\text{C}$  is produced from  $^{14}\text{N}$  when it combines with neutron.

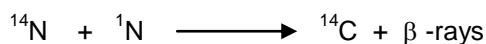

In another method isotopes are produced in a cyclotron by bombardment of the nucleus of an element with proton.

### Measurement of Radioactivity

The radioactivity of isotopes can be measured either by using counting devices or by photographic method (autoradiography).

The quantitative determination of radioactivity is based on the ionization or excitation of matter induced by radiations emanated from radioactive elements. The following are the important instruments used to determine radioactivity of substances.

### Geiger-Miuller Counter (GM Tube)

This instrument works on the principle of ionization of gases and is suitable for all kinds of radiations. The structure of **GM tube** is schematically shown in the Fig. 29. It consists of a simple and very Compact ionization chamber made of glass with two electrodes. It is filled with a gas **usually argon, neon** or air. The outer electrode (cathode) is a metal tube formed by brass or nickel with 1-5 cm diameter and 10-50 cm length. The inner electrode (anode) is a fine wire of **tungsten** with 0.1-0.5 mm thickness. The tube is stretched along the axis of the tube and well-insulated by ebonite plugs. When radiation enters the tube, the gas is ionized rapidly under a high voltage power supply resulting in an electric pulse. However, the discharge of the pulse terminates when large quantity of positive ions get collected around the negative electrode and this prevents the occurrence of further ionization. To accelerate the process of ionization, GM tubes contain a quenching gas. However, presence of a quenching gas and the window through which the particles pass into the tube restrict the entrance of radiation thereby reducing the efficiency of the detector. To overcome this problem, GM tubes with very thin windows or with no windows have been developed. However, the windowless GM tubes require a continuous flow of special quenching gas through the tube.

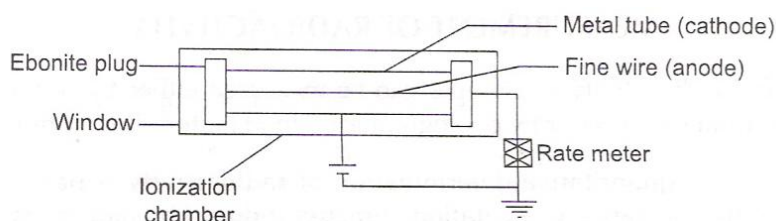

Fig. 29. Diagrammatic structure of GM tube.

### Proportional Counter

It is a modified GM tube which operates in a region of applied current where the charge produced is proportional to the initial ionization. This device is more advantageous than GM counter because it has greater stability and reproducibility and can operate at reduced voltage. The consumption of quenching gas is lesser in proportional counter than in GM tube. This device produces continuous pulses which enable very fast counting. The most popular proportional counter is the 'flow counter' in which a gas like argon or indane is continuously passed through an open-ended tube of ionization chamber at pressure slightly higher than that of the atmosphere.

## 4. Scintillation Counter

This apparatus is more sensitive and efficient than the GM tube and is mostly used in detecting  $\beta$ -rays. It uses certain fluorescent crystals, which emit light in the form of scintillations on absorbing radiation. The main parts of this counter are schematically shown in Fig. 30. Phosphor is usually used as scintillating substance. Natural inorganic crystals (Zinc sulphide or calcium tungstate) and certain organic liquids as well as plastics are also used as phosphors. Inorganic phosphors are mainly used to detect protons, deuterons and  $\gamma$  rays whereas organic phosphors are used to detect particles. These substances when exposed to

radiation scintillate and emit flashes of light. These light pulses are converted into electric pulses, which are amplified and recorded.

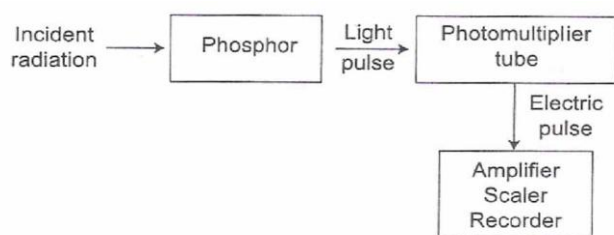

Fig. 30. Schematic representation of scintillation counter.

### 5. Liquid Scintillation Counter

This device is highly efficient in counting very weak  $\gamma$  -rays. Here the radioactive material is dissolved in a liquid containing a phosphor which interacts with  $\gamma$  particles resulting in the emission of light flashes.

This device is highly efficient in counting very weak  $\gamma$  -rays. Here the radioactive material is dissolved in a liquid containing a phosphor which interacts with  $\gamma$  particles resulting in the emission of light flashes.

Recently many types of scintillation counters have been devised to study cosmic rays.

### 6. Crystal Counter

In this **radioactive counter**, photo conductivity of crystals is utilized to determine the radioactivity of substances. The diagrammatic structure of a crystal counter is shown in Fig. 31.

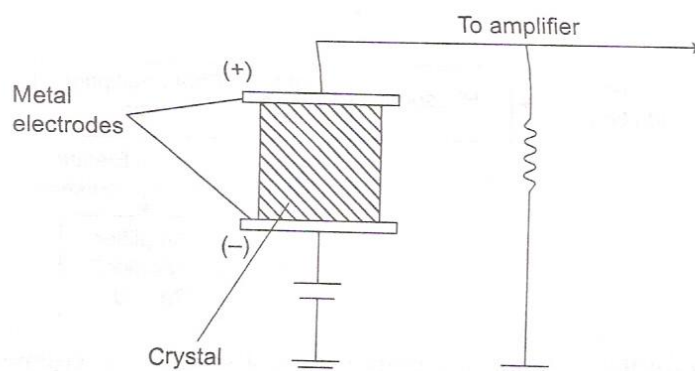

Fig. 31. Diagrammatic structure of crystal counter.

It consists of a **natural crystal** (diamond or silver chloride or lithium fluoride), which is mounted between two metal electrodes maintained at high voltage. Nowadays semiconductors like silicon **crystals** are also used. When radiation is allowed to pass across the crystal, electrons are expelled from the atoms of the crystal and accelerated towards the positive electrode. On their way, the accelerated electrons hit more electrons. As a result, a bunch of electrons reaches the electrode with the production of a corresponding pulse.

#### Method of Detection of Disintegration Frequency

In all detectors, the disintegration frequency of **radioactive substances is counted either by a scaler or by a count rate meter**. A scaler is an electronic device, which counts the number of pulses from the counter equipments. The count rate meter converts the counts into counts per minute, which are read directly. **A spectrophotometer is also used between the counter and scaler or rate meter to differentiate pulses of different amplitudes.**

#### Biological Effects of Radiation

$\alpha$ ,  $\beta$  and  $\gamma$  rays as well as neutrons cause **harmful effects on living organisms** due to ionization of atoms within the cells. In other words, ionization alters or destroys cellular constituents and **causes nuclear-cytoplasmic swelling, breakage of chromosomes and so on**. In general, the effects of radiation can be categorized into three types. The **recoverable effects or short-term effects** are due to small doses of radiations and include skin disorders and loss of hair. **(Short-term recoverable effects)**. The **irrecoverable effects or long-term effects** are due to larger doses of radiations and include bone marrow

damage, cell damage, leukemia, cancer, etc. (**long-term irrecoverable effects**). The **genetic effects** appear only in future generations of irradiated individuals and cause deterioration of quality at population level by way of producing unusual offsprings.

## 5.2. APPLICATION OF RADIOISOTOPES IN BIOLOGICAL SCIENCES

Radioisotopes have been using in various biological field and are highly diversified such as agriculture, tumor therapy, immuno- diagnostic and food industry.

### Isotopes in trace technique

In order to understand biochemical reactions. It is very essential to use radioisotopes in tracking metabolic pathways. For example certain compounds like glucose are labeled with  $^{14}\text{C}$  ( $^{14}\text{C}$  glucose ) and amino acids  $^{15}\text{N}$  glutamate using isotopes as tracers several. Major metabolic pathways have been elucidated like carbon dioxide fixation in plants during photosynthesis, central metabolic pathways, synthesis of nucleic acid, process of DNA replication. In medical biochemistry these are widely used in studying the action of branching enzyme of glucogenesis by  $^{14}\text{C}$  labeled glucose tracer. An isotopic tracer is used to understand the degradative product of a given compound like uric acid, an end product of purine degradation has been established using  $^{14}\text{C}$ - labeled guanine as the tracer. The rate of synthesis of DNA or replication has been determined using an  $^3\text{H}$  labeled thymidine tracer. It can through light on the metabolic abnormalities and sites of destruction. It also provide information on the rate of absorption and defects of a given mineral using labeled mineral ( $^{59}\text{Fe}$ ) in interstine.

Isotopes are used in the measurement of body mass, body water and extracellular fluid using  $^3\text{H}$  labeled tritium oxide,  $^{14}\text{C}$  labeled uric acid and  $^{51}\text{Cr}$  for erythrocyte volume.

### Isotopes in Radioimmuno Assay (RIA)

It is extremely difficult to measure the presence of hormones in the blood as their concentration is in nano or picomole. Applying isotopes in a technique known as radioimmuno assay (RIA) is possible to detect picomoles or femto mole amounts of hormones or any other compounds. In RIA antigen are labeled in antigen antibody complex. The hormone is allowed to react with labeled antigen-antibody complex. The amount of hormone in the sample is calculated by measuring the amount of labeled antigen displaced.

### Isotopes in organ functions and Imaging

Radioisotopes are used to study functions of thyroid and kidney. Using  $^{131}\text{I}$  the thyroid function is assessed. Rate of synthesis and elimination of thyroxine hormone can be measured using radiolabelled hippuric acid, kidney function is assessed. In organ imaging, isotopes such as  $^{131}\text{I}$  is used to obtain images of the lung and thyroid.

### Radiation and isotopes in agriculture

Radioisotopes are indispensable in studying the mode of ion uptake by root system from the soil. Radiation is employed to induce mutations in order to improve crop productivity in agriculture. Calibrated dosage of  $\gamma$ -irradiated seeds or plants are employed in process of mutation breeding.

### Isotopes in Food Industries

In food industry isotopes are used to increase the shelf life of foods and dairy products. For example, pasteurized milk is exposed to radiation has a longer shelf life. Several foods are sterilized by exposing to radiation before packaging is done. Radiosterilised foods have an increased shelf life.

### Isotopes in Cancer Therapy

Radiation have been using in the treatment of cancer since long time. Tumor cells are sensitive to radiation compared to normal cells. Isotopes such as  $^{131}\text{I}$  is used in the treatment of thyroid cancer and  $^{60}\text{Co}$  is extensively used in the treatment of tumors located deep inside the body. For skin cancer and leukemia  $^{32}\text{P}$  is widely used.

### Metabolic Application

**Metabolic pathways:** Radioisotopes are frequently used for tracing metabolic pathways. This usually involves adding a radioactive substrate, taking samples of the experimental material at various times, extracting and chromatographically, or otherwise, separating the products. Radioactivity detectors can be attached to gas-liquid chromatography or high performance liquid chromatography columns to monitor radioactivity coming off the column during separation. Alternatively, radioactivity can be located on paper or thin-layer chromatography with either a Geiger-Muller chromatograph scanner or with autoradiography. If it is suspected that a particular compound is metabolised by a particular pathway, then radioisotopes can also

be used to confirm this. For instance, it is possible to predict the fate of individual carbon atoms of [ $^{14}\text{C}$ ] acetate through the **tricarboxylic acid, or Krebs cycle**. Methods have been developed whereby intermediates of the cycle can be isolated and the distribution of carbon within each intermediate can be ascertained. This is the so-called specific labelling pattern. Should the actual pattern coincide with the theoretical pattern, then this is very good evidence for the mode of operation of the Krebs cycle.

Another example of the use of radioisotopes to confirm the mode of operation, or otherwise, of a metabolic pathway is in studies carried out on **glucose catabolism**. There are numerous ways whereby glucose can be oxidised, the two most important ones in aerobic organisms being **glycolysis** followed by the Krebs cycle together with the pentose phosphate pathway. Frequently, organisms or tissues possess the necessary enzymes for both pathways to occur and it is of interest to establish the relative contribution of each to glucose oxidation. Both pathways involve the complete oxidation of glucose to carbon dioxide, but the origin of the carbon dioxide in terms of the six carbon atoms of glucose is different (at least in the initial stages of respiration of exogenously added substrate). Thus, it is possible to trap the carbon dioxide evolved during the respiration of specifically labelled glucose (e.g. [ $6\text{-}^{14}\text{C}$ ] glucose or [ $1\text{-}^{14}\text{C}$ ] glucose in which only the stated atom is radioactive) and obtain an evaluation of the contribution of each pathway to glucose oxidation.

The use of radioisotopes in studying the operation of the **Krebs cycle** or in evaluating the pathway of **glucose catabolism** are just two examples of how such isotopes can be used to confirm metabolic pathways.

**Metabolic turnover times:** Radioisotopes provide a convenient method of ascertaining turnover times for particular compounds. As an example, the turnover of proteins in rats will be considered. A group of rats is injected with a radioactive amino acid and left for 24 h, during which time most of the amino acid is assimilated into proteins. The rats are then killed at suitable time intervals and radioactivity in organs or tissues of interest is determined. In this way it is possible to ascertain the rate of metabolic turnover of protein. Using this sort of method, it has been shown that liver protein is turned over in 7 to 14 days, while skin and muscle protein is turned over every 8 to 12 weeks, and collagen is turned over at a rate of less than 10% per annum.

**Studies of absorption, accumulation and translocation:** Radioisotopes have been very widely used in the study of the mechanisms and rates of absorption, accumulation and translocation of inorganic and organic compounds by both plants and animals. Such experiments are generally simple to perform and can also yield evidence on the route of translocation and sites of accumulation of molecules of biological interest.

**Pharmacological studies:** Another field where radioisotopes are widely used is in the development of new drugs. This is a particularly complicated process, because, besides showing whether a drug has a desirable effect, much more must be ascertained before it can be used in the treatment of clinical conditions. For instance, the site of **drug accumulation, the rate of accumulation, the rate of metabolism and the metabolic products** must all be determined. In each of these areas of study, radiotracers are extremely useful, if not indispensable. For instance, autoradiography on whole sections of experimental animals yields information on the site and rate of accumulation, while typical techniques used in metabolic studies can be used to follow the rate and products of metabolism.

## Analytical Applications

### Enzyme and ligand binding studies

Virtually any enzyme reaction can be assayed using radiotracer methods, provided that a radioactive form of the substrate is available. Radiotracer-based enzyme assays are more expensive than other methods, but frequently have the advantage of a higher degree of sensitivity. Radioisotopes have also been used in the study of the mechanism of enzyme action and in ligand binding studies.

### Isotope dilution analysis

There are many compounds present in living organisms that cannot be accurately assayed by conventional means because they are present in such low amounts and in mixtures of similar compounds. Isotope dilution analysis offers a convenient and accurate way of overcoming this problem and avoids the necessity of quantitative isolation. For instance, if the amount of iron in a protein preparation is to be determined, this may be difficult using normal methods, but it can be done if a source of Fe is available. This is mixed with the protein and a sample of iron is subsequently isolated, assayed for total iron and the radioactivity determined.

If the original specific activity was  $10\,000\text{ d.p.m. (10 mg)}^{-1}$  and the specific activity of the isolated iron was  $9000\text{ d.p.m. (10 mg)}^{-1}$  then the difference is due to the iron in the protein, (x), i.e.

$$\frac{9000}{10} \times \frac{10000}{10}$$

Therefore  $x = 1.1 \text{ mg } \mu$ .

This technique is widely used in, for instance, studies on trace elements.

### Radioimmunoassay

One of the most significant advances in **biochemical techniques** in recent years has been the development of radioimmunoassay.

### Radiodating

A quite different analytical use for radioisotopes is in the **dating (i.e. determining the age) of rocks, fossil and sediments**, in this technique it is assumed that the proportion of an element that is naturally radioactive has been the same throughout time. From the time of fossilisation or deposition, the radioactive isotope will decay. By determining the amount of radioisotope remaining (or by **examining the amount of a decay product**) and from a knowledge of the half-life, it is possible to date the sample. For instance, if the radioisotope normally composes 1% of the element and it is found that the sample actually contains 0.2511% then two half lives can be assumed to have elapsed since deposition. If the half-life is one million years then the sample can be dated as being two million years old.

For long-term dating, isotopes with long half-lives are necessary such as  $^{235}\text{U}$ ,  $^{238}\text{U}$  and  $^{40}\text{K}$ , whereas for shorter-term dating  $^{14}\text{C}$  is widely used. It cannot be over emphasised that the assumptions made in; **radiodating are sweeping and hence palaeontologists and anthropologists who use this technique** can give only approximate dates to their samples.

### Other Applications

#### Molecular biology techniques

Recent advances in molecular biology that have led to advances in genetic manipulation have depended heavily upon use of radioisotopes in **DNA and RNA sequencing, DNA replication, transcription, synthesis of complementary DNA, recombinant DNA technology and many similar studies**.

#### Clinical diagnosis

Radioisotopes are very widely used in medicine, in particular for diagnostic tests. Lung function tests routinely made using xenon- $^{133}$  ( $^{133}\text{Xe}$ ) are particularly **useful in diagnosis of malfunctions of lung ventilation. Kidney function tests using [ $^{133}\text{I}$ ] Iodohippuric acid** are used in diagnoses of kidney infections, kidney blockages or imbalance of function between the two kidneys. **Thyroid function** tests using  $^{133}\text{I}$  are employed in the diagnosis of hypo- and hyperthyroidism.

Various aspects of **haematology are also studied by using radioisotopes**. These include such aspects as **blood cell lifetimes, blood volumes and blood circulation times**, all of which may vary in particular clinical conditions.

#### Ecological studies

The bulk of radiotracer work is carried out in biochemical, clinical or pharmacological laboratories, nevertheless, radiotracers are also of use to ecologists. In particular, migratory **patterns and behaviour patterns of many animals can be monitored using radiotracers**. Another ecological application is in the **examination of food chains where the primary producers can be made radioactive** and the path of radioactivity followed throughout the resulting food chain.

#### Sterilisation of food and equipment

Very strong  $\gamma$  emitters are now widely used **in the food industry for sterilisation of prepacked foods such as milk and meats**. Normally either  $^{60}\text{C}$  or  $^{137}\text{Ce}$  is used, but care has to be taken in some cases to ensure that the food product itself is not affected in any way. Thus, doses often have to be reduced to an extent where sterilisation is not complete but food spoilage can be greatly reduced.  $^{60}\text{C}$  or  $^{137}\text{Ce}$  are also used in **sterilisation of plastic disposable equipment such as Petri dishes and syringes**, and in sterilisation of drugs that are administered by injection.

#### Mutagens

**Radioisotopes may cause mutations**, particularly in microorganisms. In various microbiological studies, **mutants are desirable, especially in industrial microbiology**. For instance, developments of

new strains of a microorganism that produce higher yields of a desired microbial product frequently involve mutagenesis by radioisotopes.

### 5.3. AUTORADIOGRAPHY

Autoradiography is an important technique by which the routes and conversion of molecules in **biochemical reactions occurring in cells are traced**. The radioactive isotopes are stable only for definite periods and then they decompose to form other atoms or fragments of atoms. During **this radioactive decay, many atoms produce radioactive emissions, which may be measured by special devices**.

#### Principles of autoradiography

Autoradiography is a procedure for localizing and recording a radiolabeled compound within a solid sample, which involves the production of an image in a photographic emulsion. In molecular genetic applications, the solid sample often consists of size-fractionated DNA or protein samples that are embedded within a dried gel, fixed to the surface of a dried nylon membrane or nitrocellulose filter, or located within fixed chromatin or tissue samples mounted on a glass slide. The photographic emulsions consist of silver halide crystals in suspension in a clear gelatinous phase. Following passage through the emulsion of a  $\beta$ -particle or a  $\gamma$ -ray emitted by a radionuclide, the  $\text{Ag}^+$  ions are converted to Ag atoms. The resulting latent image can then be converted to a visible image once the image is developed, an amplification process in which entire silver halide crystals are reduced to give metallic silver. The fixing process results in removal of any unexposed silver halide crystals, giving an autoradiographic image which provides a two-dimensional representation of the distribution of the radiolabel in the original sample.

Direct autoradiography involves placing the sample in intimate contact with an X-ray film, a plastic sheet with a coating of photographic emulsion; the radioactive emissions from the sample produce dark areas on the developed film. This method is best suited to detection of weak to medium strength  $\beta$ -emitting radionuclides (e.g.  $^3\text{H}$ ,  $^{35}\text{S}$ , etc.). However, it is not suited to high energy  $\beta$ -particles (e.g. from  $^{32}\text{P}$ ): such emissions pass through the film, resulting in the wasting of the majority of the energy.

Indirect autoradiography is a modification in which the emitted energy is converted to light by a suitable chemical (scintillator or fluor). One popular approach uses intensifying screens, sheets of a solid inorganic scintillator which are placed behind the film in the case of samples emitting high energy radiation, such as  $^{32}\text{P}$ . Those emissions which pass through the photographic emulsion are absorbed by the screen and converted to light. By effectively superimposing a photographic emission upon the direct autoradiographic emission, the image is intensified.

In this technique, the sample containing **radioactive substance (a chromatogram or a tissue slice or a section of a plant or animal) is kept in close contact with a photographic plate or an X-ray film**. That is, the cells or tissues already exposed to radioactive isotopes are made to contact with a photographic emulsion for specific period as shown in the Fig. 32.

The emanating radiations affect the emulsion in the same way like that of light. On development, the areas, which have been in contact with radioactivity, could appear as spots on the film, thus producing the image of the specimen.

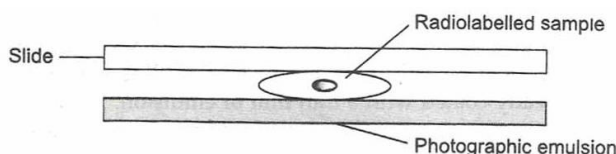

Fig. 32. Contact between radiolabelled sample and photographic emulsion.

#### Autoradiographic Method

##### 1 Specimen Preparation for Autoradiography

Typically, **small precursor molecules**, which are utilized by the cells as building blocks of macromolecules, are incorporated with radioactive isotopes. This is usually carried out by injecting suitable amount of a dilute radioactive solution into the animal (if required, repeatedly). Then the animal is anaesthetized and a specific tissue is dissected out after a period of time for fixation. The choice of fixation and fixatives depends on the chemical composition of the sample material to be studied. For example, nucleoproteins are fixed in Carnoy's acetic alcohol. The tissues are quickly frozen and dried in vacuum desiccators to obtain all the incorporated radioactive molecules. The incorporation of a radioactive isotope into RNA of cells requires the extraction of all DNA molecules from the tissue. Similarly, the study of DNA necessitates the removal of all RNA molecules from the tissues.

For tissues, the usual paraffin sections of 2-4 thickness are made by routine microtechnique method. **Smears and frozen sections can also be radiolabelled and studied.**

### Methods to Make Contact between Specimen and Photographic Emulsion

In general, three methods are employed to make contact between the specimen and photographic plate.

**i) Opposition method** This method is used to study single cells and the contact of the specimen with photographic emulsion is made in dark. First, the paraffin sections are allowed to float on the warm water and then picked up on a microscopic slide, which is already coated with a thin film of emulsion. Now the sections remain attached to the slide and are processed, stained and mounted.

**ii) Liquid-emulsion method** Here, the slides with deparaffinized sections, cell smears or blood films are simply dipped in molten liquid emulsion, dried in a light-tight box and kept in refrigerator for desired period of exposure. Then the slides are developed in dark room, fixed, stained and examined under phase contrast microscope.

**iii) Stripping-film method** The special stripping film meant for autoradiography is cut into a square in dark room and is floated in distilled water contained in a cylindrical glass jar with the emulsion side facing downwards. The deparaffinized slide containing the sections is immersed in water below the filmstrip and lifted out of water in such a way that the film covers the specimen. Then the slide is dried, stored in dark for exposure, developed, fixed, stained and observed under phase contrast microscope.

Rat brain sections labelled with 3H QNB (muscarinic receptor ligand) were exposed to both the BAS 3000 phosphor plate imager and autoradiographic film (Fig. 33). The image demonstrates the use of a high resolution phosphor imager (the BAS 3000 is a 50 um machine) for quantitative receptor binding.

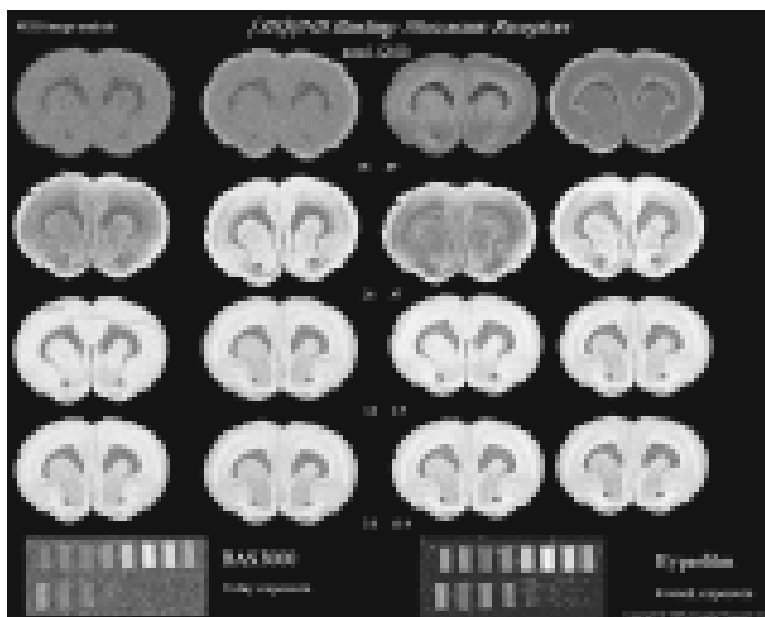

Fig. 33. Autoradiography sample images.

### Uses Autoradiography

Uses Autoradiography is useful in the study of the movement of solutes in tissues, to determine the rate of production and life span of blood cells and to identify thyroid function and cancer cells.

Autoradiography can be used to demonstrate a number of biochemical processes. For example, if  $^{14}\text{C}$ -labelled amino acids are given to the cells growing in a culture, one can observe an increase in the number of grains with time because the labeled amino acids is stopped, and unlabelled amino acids are given the supply, the amount of radioactive protein in the cells will decrease and eventually disappear as radioactive protein is degraded and excreted. Since the new proteins are synthesized with unlabelled amino acids, the grains will not appear in the autoradiographic emulsion.

This technique has made many contributions in the study of cell metabolism as given in Table 8.

Table 8 Contributions of autoradiography to basic cell metabolism.

Radiolabelled substances	Events in cell metabolism
C <sup>14</sup> labelled glycine	Synthesis of RNA from nucleolus, protein synthesis
H <sup>3</sup> labelled thymidine	Metabolism of chromosomal DNA, cell turnover times, DNA metabolism in salivary gland chromosomes
H <sup>3</sup> labelled cytidine	Nucleic acid metabolism during regeneration
H <sup>3</sup> labelled cytidine and thymidine and C <sup>14</sup> labelled glycine	Changes in nucleic acids and protein metabolism during meiosis in plants
C <sup>14</sup> labelled adenine	nucleic acid metabolism during animal spermatogenesis

In **medicine**, this technique is useful to diagnose circulatory disorders, bone defects, tumours and so on. Some like I<sup>131</sup> is used to treat thyroid defects, p<sup>32</sup> to treat skin diseases and Co<sup>60</sup> to treat tumours. In **agriculture**, the incorporation of radiolabelled fertilizers to the soil increases crop yields. Radioisotopes are also used to preserve vegetables and cereals. Radiation is used to sterilize **pharmaceutical** and surgical instruments. The isotope of carbon is useful in **archaeological dating** to estimate the age of earth.

#### 5.4. SPECTROSCOPIC TECHNIQUES

The interaction between electromagnetic radiation and matter forms the 'basis for spectroscopy. When the electromagnetic radiation having a particular frequency is passed through a sample, the frequency which is absorbed or emitted by the molecules of the sample, is determined at molecular energy level by analysing the intensity of frequency emerging out of the sample. The instrument called **spectrometer** measures the change in intensity of electromagnetic radiation. The results are interpreted in terms of stereochemistry of the molecule (three-dimensional spatial arrangements of atoms in a molecule).

The spectrum obtained by the interaction in which a sample itself emits radiation is called **emission spectrum**. The spectrum obtained by the interaction in which the sample absorbs radiation is called **absorption spectrum**. When atoms absorb electromagnetic radiation, their electronic energy is increased resulting in a spectrum in the form of spectral lines of varying wavelength. This is **atomic absorption**. On absorption of electromagnetic radiation, the molecules become excited. When the molecules return to their original ground state, they emit molecular spectrum in the form of bands, each line of which is composed of a large number of very fine lines. This process is called **molecular absorption**. The energy associated with the uniform motion of a molecule is called **translational energy**. A molecule also possesses some forms of internal energy including **rotational energy**, which is due to the overall rotation of molecules, **vibrational energy** which is associated with the oscillation of atoms of the molecule, and **electronic energy** which is due to the movement of electrons. In a molecule, the levels of rotational energy are closely spaced so that very little energy is required for rotational transitions. This occurs in infrared, microwave regions of the electromagnetic spectrum, and is useful in the study of molecular structure. The vibration energy levels are spaced apart and occur in infrared region of the spectrum, when molecules absorb photons of electromagnetic radiation in the visible and ultraviolet regions, the electronic energy is increased causing rotational and vibrational changes. As a result, the molecular spectrum exhibits a band of wavelengths.

## 5.5. GENERAL PRINCIPLES OF VISIBLE AND ULTRAVIOLET SPECTROSCOPY

### Visible Spectrum

Light from the sun contains the entire visible spectrum. This continuum of light appears “white” or colourless. Objects that appear coloured absorb light at particular wavelength and reflect the other parts of the visible spectrum, thus giving rise to many “shadings” of colour. For example, a substance that absorbs violet light at 400 nm reflects all other light and appears as yellow green. A substance absorbing yellow light at 590 nm is seen as blue which is the sum of the reflected light. The details of the visible spectrum are given in the following Table 9.

Table 9. The details of visible spectrum.

Approximate Wavelength (nm)	Colour of light absorbed	Colour of light reflected
400-435	Violet	Green – Yellow
435-500	Blue	Yellow
500-570	Green	Red
570-600	Yellow	Blue
600-630	Orange	Green-Blue
630-700	Red	Green

### UV –Visible ranges of the spectrum

Electromagnetic radiation is produced by many types of events occurring at the molecular, atomic or nuclear level. Since each of these events differs in terms of the energy involved, the radiation it emits, will have different wavelength.

Vaccum UV (2-180 nm), UV (180-400nm), and visible (400-780 nm) ranges of spectrum are produced due to the transitions which occur at the valence electron level.

### UV region

The following types of orbital are generally found in the ground states of organic molecules:

- Bonding  $\sigma$  orbitals
- Bonding  $\pi$  orbitals
- n- orbitals

All the above three types are illustrated by taking formaldehyde as an example

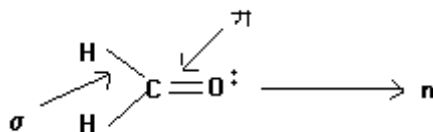

According to molecular orbital theory, when a molecule is excited by the absorption of energy (UV or visible light), its electrons are promoted from a bonding to an anti-bonding orbital (higher energy levels). The anti-bonding orbital associated with the  $\sigma$  bond is called  $\sigma^*$  orbital and that associated with  $\pi$  bond is known as the  $\pi^*$  orbital. Since non-bonding electrons are not directly involved in bonding, there is no corresponding anti-bonding orbital for them. The major electronic transitions that take place within the UV and visible regions are

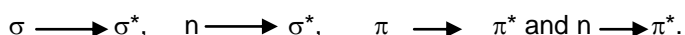

The energies associated with these transitions are given below, in the decreasing order.

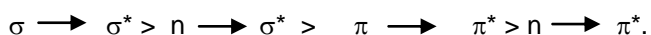

Comparatively lower energy is required for  $\pi - \pi^*$  transitions. These transitions take place in the unsaturated centers of molecules. Since these transitions are associated with a lower energy, they take place at comparatively longer wavelengths. They show absorption in the normal ultraviolet region (180 – 400nm).

The lowest energy transition is that between the highest occupied molecular orbital (HOMO) and the lowest unoccupied molecular orbital (LUMO) in the ground state. The absorption of the EM (electromagnetic) radiation excites an electron to the LUMO and creates an excited state. The more highly conjugated the system, the smaller the HOMO-LUMO gap,  $\Delta E$ , and therefore the lower the frequency and longer the wavelength,  $\lambda$ . The colours we see in inks, dyes, flowers *etc.* are typically due to highly conjugated organic molecules. The unit of the molecule that is responsible for the absorption is called the **chromophore**, of which the most common are C=C ( $\pi$  to  $\pi^*$ ) and C=O (n to  $\pi^*$ ) systems

### General Principle

Spectrophotometry (visible and UV) works on the principles of Lambert and Beer's law.

### Lambert-Beers law

The absorption of light by any absorbing material is governed by two laws. The first law of absorption is known as the Lambert law. It states that the amount of light absorbed is proportional to the thickness of the absorbing material and is independent of the incident light. Accordingly,

$$I/I_0 = e^{-kx}$$

Where I is the intensity of the transmitted light

$I_0$  is the intensity of the incident light.

x is the absorbing thickness or path length and

k is the linear absorption coefficient of the absorbing material.

The power term in the above relationship is removed by converting to the logarithmic form. So,

$$2.303 \log_{10} I_0 / I = kx.$$

The second law of absorption is known as the Beer's law. This law states that the amount of light absorbed by a material is proportional to the number of absorbing molecules (i.e. the concentration of the absorbing solution). Accordingly,

$$\log_{10} I_0 / I = k' c$$

where  $k'$  is absorptivity constant and c is the concentration of the absorbing material.

By combining the above two laws, k and  $k'$  merge to become a single constant.

$$\log_{10} I_0 / I = \epsilon c x$$

This equation is referred to as Beer-Lambert law or Beer's law. This combined law states that the amount of light absorbed is proportional to the concentration of the absorbing substance and the thickness of the absorbing material. The quantity  $I_0 / I$  is known as the absorbance or the optical density. The reverse,  $I / I_0$  is known as the transmittance.

### Molar extinction coefficient

According to Beer-Lambert's law, the absorbance is proportional to both the concentration of the substance present and thickness of the absorbing layer.

$$A = abc$$

Where a is the absorbance coefficient or extinction coefficient for the substance at wavelength  $\lambda$ .

c is the concentration of absorbing solution and

b is the path length of the solution.

If c is expressed in gram moles per liter and b is expressed in centimeters, the absorbance coefficient, a becomes ' $a_m$ ' which is known as molar extinction coefficient or molar absorptivity

$$A = a_m bc$$

$$a_m = A / bc.$$

Where A is the absorbance.

Molar extinction coefficient is a physical constant for a given compound if the solvent and wavelength are defined.

## Percentage Transmission and Absorption

When a light of an appropriate wavelength strikes a cuvette that contains a coloured sample, some of the light is absorbed by the solution. In general, objects that appear coloured absorb light at particular wavelength and reflect the other parts of the visible spectrum. After absorption the rest of the light is transmitted through the sample to the detector. The proportion of the light that reaches the detector is known as the percent transmission (%T) and represented by the equation.

$$I_t / I_0 \times 100 \quad \% T$$

In which  $I_0$  is the intensity of light striking the sample and  $I_t$  is the intensity of the light transmitted through the sample. The relationship between concentration and %T is not linear. The term absorbance (A) is used to represent the logarithm of  $1 / \% T$  or  $(-\log \% T)$ . Absorbance increases linearly with concentration (Fig. 34).

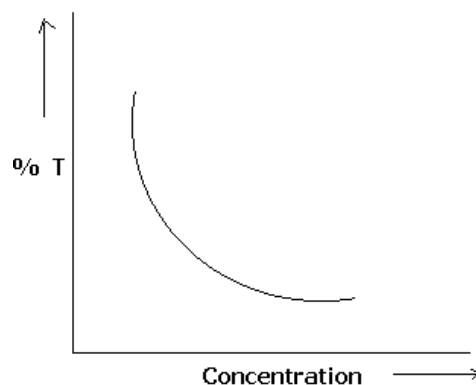

Relationship between concentration and % T

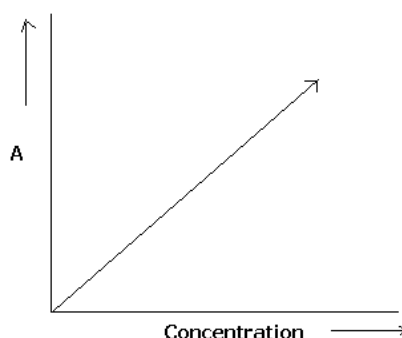

Relationship between concentration and A

Fig. 34. Percentage transmission and absorption.

## Description of Instrument

The optical system of simple spectrophotometer, *i.e.* visible and ultraviolet spectrophotometer consists of mono-chromators, cuvettes, photocells, slits and recorder, these are described as follows

### Light source

The light source is usually a tungsten lamp for the visible spectrophotometer and either a hydrogen or deuterium lamp is used in ultraviolet spectrophotometer.

When electrons in an atom are excited, radiations are absorbed resulting in the absorption spectrum of the atom. Similarly, when the electrons of a molecule are excited, the electronic spectrum originates due to a change in the arrangement of molecular electrons. The electronic spectra of molecules occur in the visible and ultraviolet regions of electromagnetic radiation. A small change in electronic energy results in a large change in vibrational energy, which in turn results in a change in rotational energy of the molecule. In other words, the molecular electronic spectra involve change in electronic, vibrational and rotational energy of the molecule. The **UV absorption spectra** are due to the transition state of an electron or electrons within a molecule or due to an ion, which occurs from a lower to higher electronic energy level. The **UV emission spectra** are due to the reversion of transition.

The ultraviolet spectrometer consists of the following components:

**Radiation source:** The source of radiation may be hydrogen, discharge lamps, deuterium lamps, xenon discharge lamps or mercury arcs. In all these lamps, the electrons are passed through a gas so that electronic vibrational and rotational excitations are produced in gas molecules.

**Monochromators:** These are dispersion elements, which may be prisms or gratings made up of glass, quartz or fused silica. The monochromator disperses radiation based on the wavelength.

**Detectors:** Three major types of detectors are used namely photovoltaic cell, photocell and photomultiplier tube.

**Photovoltaic cell:** It consists of a semiconductor (selenium) plate tightly fixed on a strong iron base (Fig. 35). The plate is coated with a thin layer of silver or gold so that it acts as an electrode. When radiation falls on the surface of the plate, electrons are produced at the selenium-silver interface and are accumulated on its silver surface. This produces electrical voltage, which is proportional to the intensity of the incident radiation.

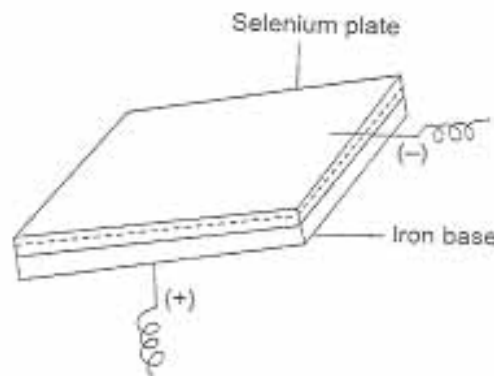

Fig. 35: A photovoltaic cell.

The emanating radiations affect the emulsion in the same way like that of light. On development, the areas, which have been in contact with radioactivity, could appear as spots on the film, thus producing the image of the specimen.

**Photocell:** It has a light-sensitive metal cathode and anode placed inside an evacuated glass tube. The inner surface of the tube is coated with light-sensitive substance (Fig. 36). When light falls on the surface coating, electrons are emitted and are reduced electrical collected by the anode. The resulting current is equal to the intensity of radiation.

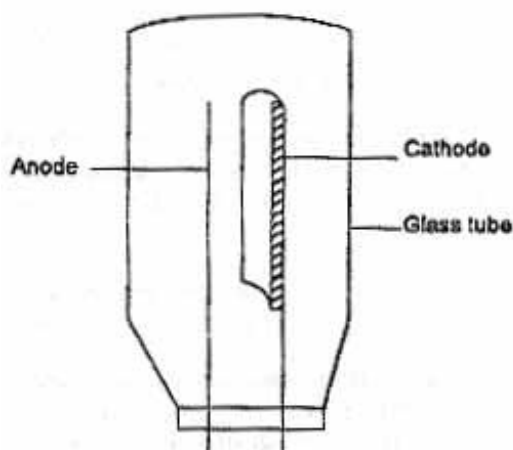

Fig. 36: A photocell.

**Photomultiplier tube:** It has an evacuated tube containing one metallic cathode and anode with many dynodes (Fig. 37). When radiation falls on the cathode, electrons are emitted and attracted by successive dynodes with the emission of more electrons at each dynode. As a result, a large number of electrons are produced and are proportional to the intensity of the falling radiation.

**Recorder:** It receives the signal from the detectors and records.

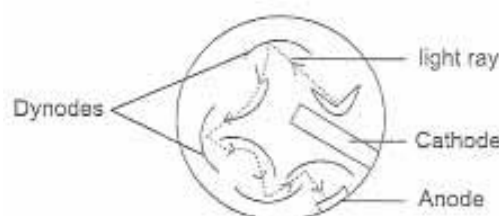

Fig. 37. Photomultiplier tube (Sectional view).

**Uses:** Visible and spectroscopy are useful in determining the concentration of biological substances. As the bases of the nucleic acids absorb UV rays, UV spectroscopy is used to study denaturation of DNA double helix. It is also employed to characterize aromatic compounds, to detect impurities in organic substances, to determine molecular weight of many compounds, to know the dissociation constant of acids and bases and to study kinetics of reactions.

**SHORT QUESTIONS**

1. Natural radioactivity
2. Electromagnetic radiation.
3. Artificial or induced radioactivity
4. Radioactive disintegration
5. Radioactive disintegration or radioactive decay
6. Half life
7. Geiger-Muller counter
8. Scintillation counter
9. Radioactive counter,
10. Isotope dilution analysis
11. Radioimmunoassay
12. Photocell:
13. Photovoltaic cell
14. Photomultiplier tube:
15. Mutagens
16. Autoradiography

**QUESTIONS**

1. What is radioactivity? Classify radioactivity with examples.
2. What is radioactive disintegration?
3. Write a note on units of radioactivity.
4. Describe the structure and functioning of Geiger-Muller counter.
5. Describe the structure and functioning of proportional counter.
6. Describe the structure and functioning of scintillation counter.
7. Describe the structure and functioning of liquid scintillation counter.
8. Describe the structure and functioning of the crystal counter.
9. What is autoradiography? Mention its principle.
10. Enumerate the steps involved in preparing the specimen for autoradiography.
11. In what ways is the contact between the specimen and photographic plate made in autoradiography?
12. Write an essay on major contributions of autography in biological studies.
13. Explain various biological effects of radiation.
14. Describe the technique of ultraviolet and visible spectroscopy.

**S.No. 7952****EDCN 202**

(For candidates admitted from 2005-2006 onwards)  
P.G. DEGREE EXAMINATION, APRIL 2006.  
Extra Disciplinary Course  
BASIC BIOTECHNOLOGY

Time: Three hours

Maximum: 75 marks

**PART A - (10 x 2 = 20)**

Answer ALL questions. Explain the following:

1. Batch fermentation.
2. Downstream processing
3. Two applications of biotechnology in food industry
4. Industrial enzymes
5. USAB
6. Two organic matter with potential for methane generation
7. Two approaches to get transgenic plants
8. Gene silencing
9. Autoradiography
10. Absorbance

**PART B - (5 x 5 = 25)**

Answer ALL questions

11. (a) Write short notes on bioreactors.  
Or  
(b) Explain any four methods for measurement of microbial growth.
12. (a) Comment on the strategies of biotechnology of dairy products.  
Or  
(b) What do you mean by immobilised enzymes?
13. (a) Highlight on production of ethanol from biomass.  
Or  
(b) Discuss the bioremediation of solid wastes.
14. (a) Briefly discuss the applications of transgenic mice.  
Or  
(b) Outline the features of human genome project.
15. (a) Mention any five applications of radioisotopes in medicine.  
Or  
(b) State and derive Beer's and Lambert's laws.

**PART C - (3 x 10 = 30)**

Answer any THREE questions.

16. Write an essay on the principle, types and production system of fermentation units.
17. Describe the different techniques available for immobilisation of enzymes.
18. Discuss the biological strategies of sewage treatment.
19. Explain in detail the biotechnology and diagnosis of animal diseases.
20. Compare and contrast visible and UV spectrophotometry.

S.No. 3194

EDCN 202

(For candidates admitted from 2005-2006 onwards)

P.G. DEGREE EXAMINATION, NOVEMBER 2006.

Extra Disciplinary Course  
BASIC BIOTECHNOLOGY

Time: Three hours

Maximum: 75 marks

**PART A - (10 x 2 = 20)**

Answer ALL questions. Explain the following:

1. Bioreactor.
2. Bioremediation.
3. Two methods for measurement of microbial growth.
4. Fermentation of foods - two applications.
5. Biohydro metallurgy.
6. MEOR.
7. HGP
8. Pronuclear injection.
9. Half life of radioisotopes,
10. One curie.

**PART B - (5 x 5= 25)**

Answer ALL questions.

11. (a) Write short notes on batch fermentation.  
Or  
b) Explain downstream processing.
12. (a) Comment on the use of microorganisms in biotechnology of food industry.  
Or  
b) Discuss the applications of immobilisation techniques.
13. (a) What do you mean by microbial mining?  
Or  
b) Explain the bioremediation of sewage water.
14. (a) What are the steps involved in the production of transgenic cattle by pronuclear injection?  
Or  
b) Explain the strategies of engineered resistance of plants against pests and insects.
15. (a) Mention any five applications of radioisotopes in biological research.  
Or  
b) Derive the relationship between absorbance and percentage transmission.

**PART C - (3 x 10 = 30)**

Answer any THREE questions.

16. Write an essay on the measurement of microbial growth.
17. Highlight on the technique of immobilisation of enzymes.
18. Justify the statement that wastes can be used as renewable source of energy.
19. Explain in detail the principle and prospects of Human Genome Project.
20. Write short notes on:
  - (a) Autoradiography.
  - (b) Clinical applications of radioisotopes.